

KUSH



schiaavello

IVAN WOODS

Schiavello and Ivan Woods have a long history. Our collaborative design process, which has evolved over many years, has yielded distinctive collections such as the Kayt and Toro collections.

Ivan enriches his designs' emotional qualities through fine detailing, influenced by a strong architectural sensibility and carefully considered geometry. The unique combination of individual and robust personalities in his products results in a unique outcome that has lent his products to a diverse range of scenarios.

Ivan grew up in Australia and studied interior architecture in Perth. Having designed interiors and products for over 30 years, he has created work for the Langham and Marriot hotels as well as international projects spanning the UK, US, Germany and Italy.



A playful collection of tailored, oversized ottomans with moveable backrest bolsters, Kush is inspired by pebbles which evokes easy living with a sense of sanctuary. Tactile and textual, Kush's laid-back flexibility offers respite in living areas and informal work settings.



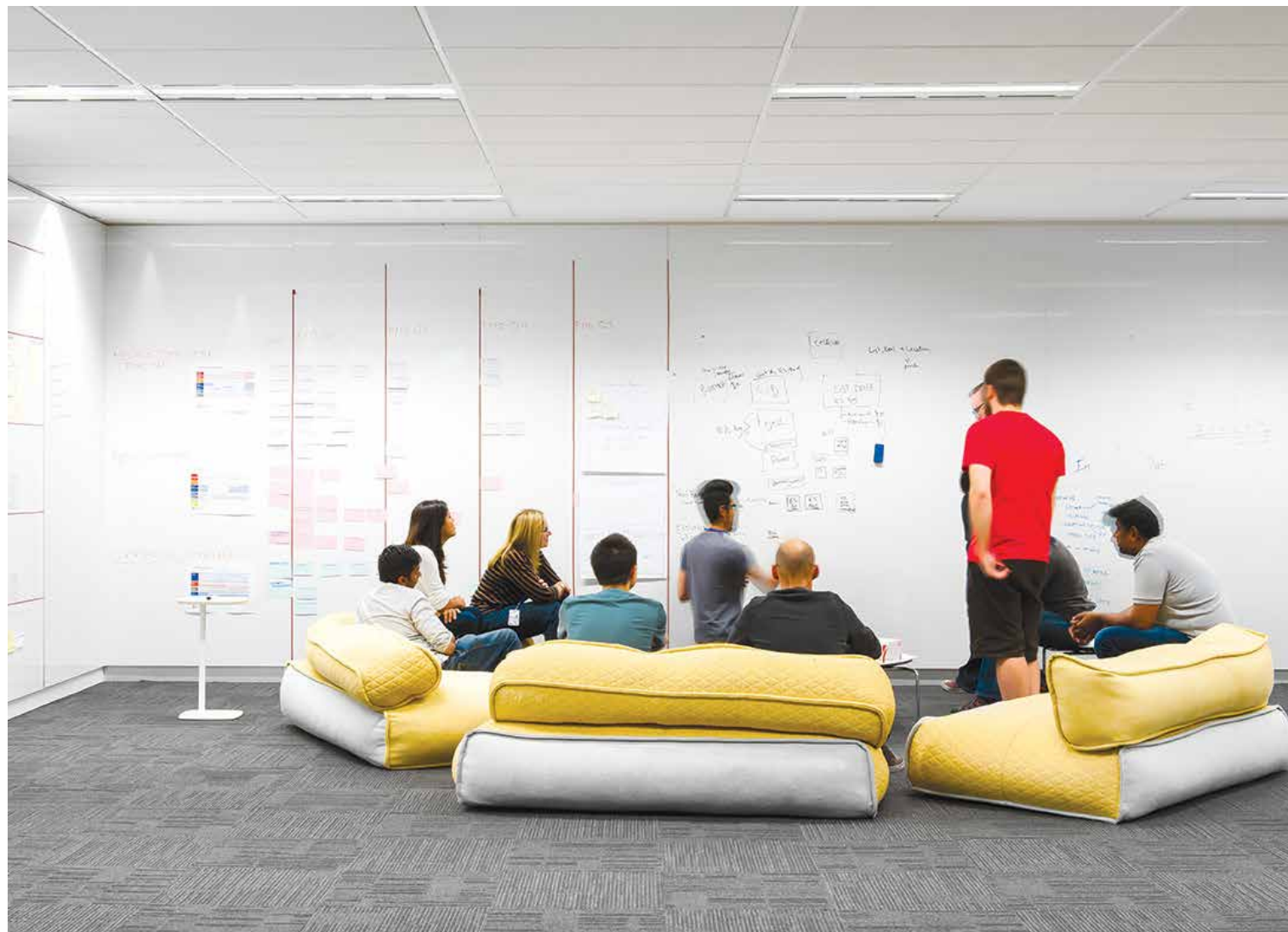

Recognising the growing trend towards the overlay between home and office settings in 2013, and the increase in breakout and lounge spaces within the workplace, Schiavello and Ivan Woods developed Kush – a relaxed, tailored, oversized ottoman.

Inspired by the thought of a pebble formation, Kush is organic in shape, materiality and feel. Tactile and textural, the ottomans provide a relaxed and laid-back seating application suitable for a variety of settings.

Kush can be designed to suit a variety of aesthetics and spaces, including office breakout areas, chill out zones in cafés, libraries, or the living area at home. It is also available in leather or a range of fabrics and colours from the Schiavello ColourLab range.

While Kush ottomans can be large in size – up to 1500mm wide – it is light and filled with foam and fibre or feather and fibre, making it easy to move around and rearrange.

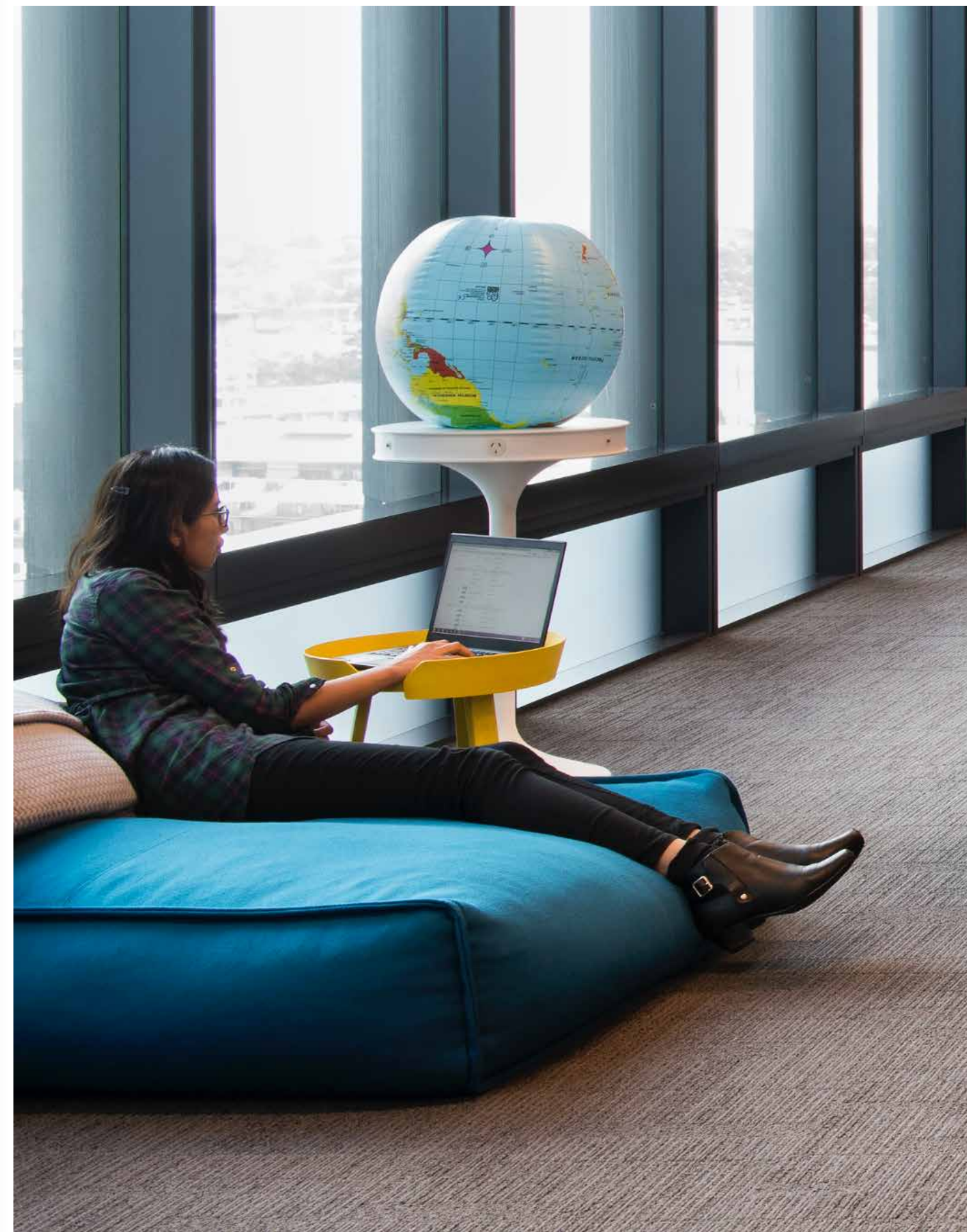



Specifications



Kush square ottoman

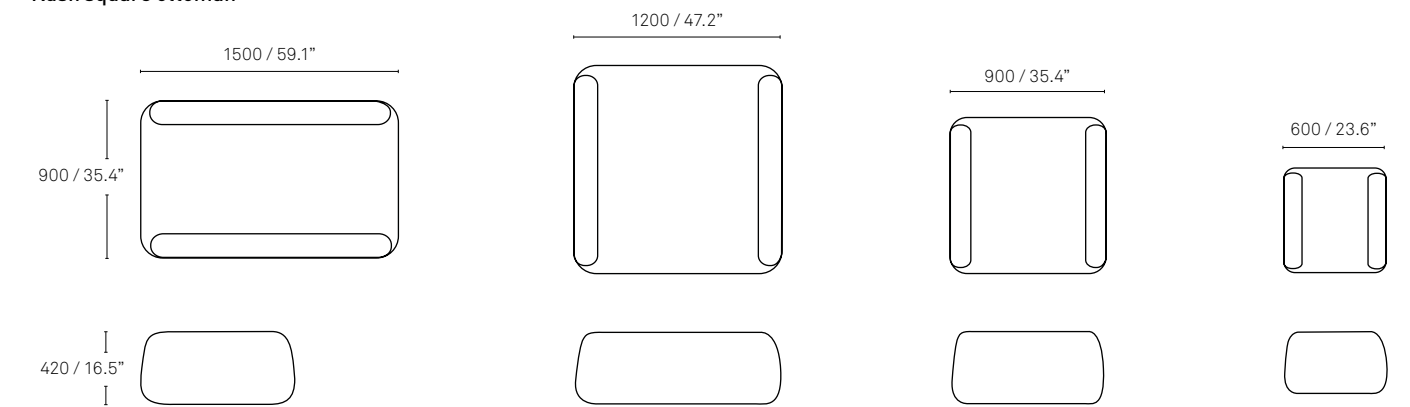

Kush organic ottoman

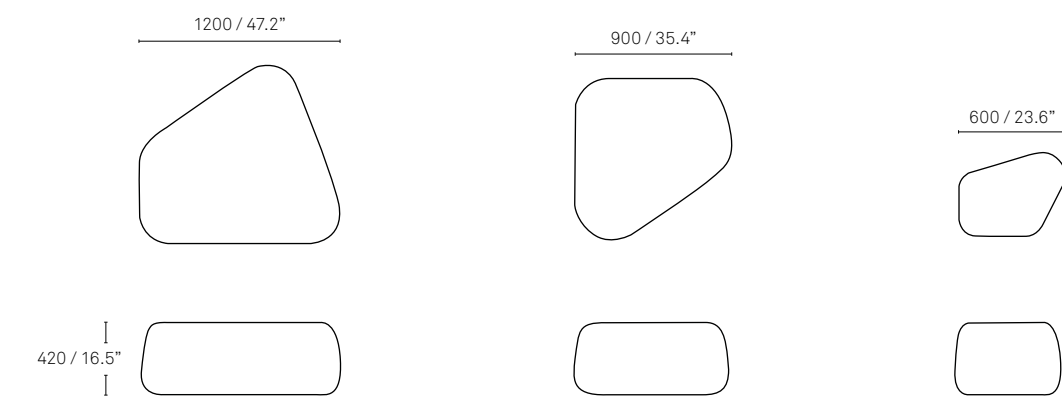

Kush back bolster

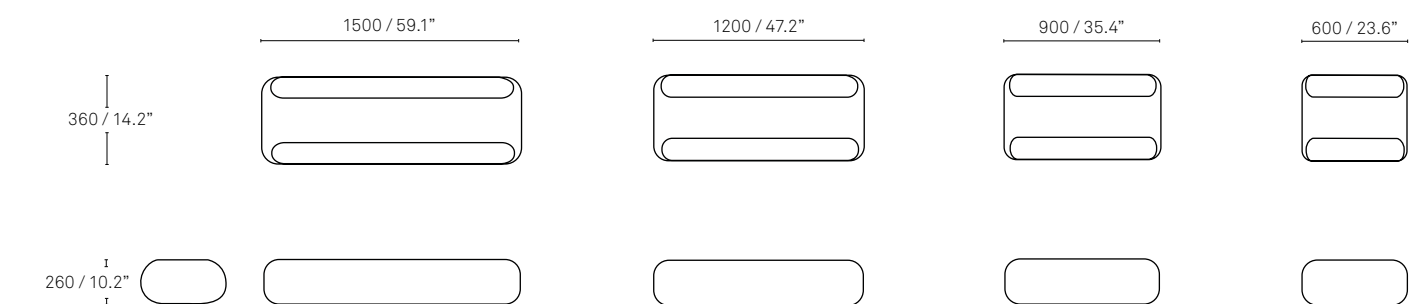

ColourLab

Schiavello's innovative ColourLab brings a considered and cohesive palette of finishes to working and living spaces. Curated by Giulio Ridolfo and developed by Schiavello, the new palette beautifully balances colour, texture and layering across a variety of materials.

CATEGORY 1
Edge, Focus
& Messenger

FABRIC

EDGE / Category 1

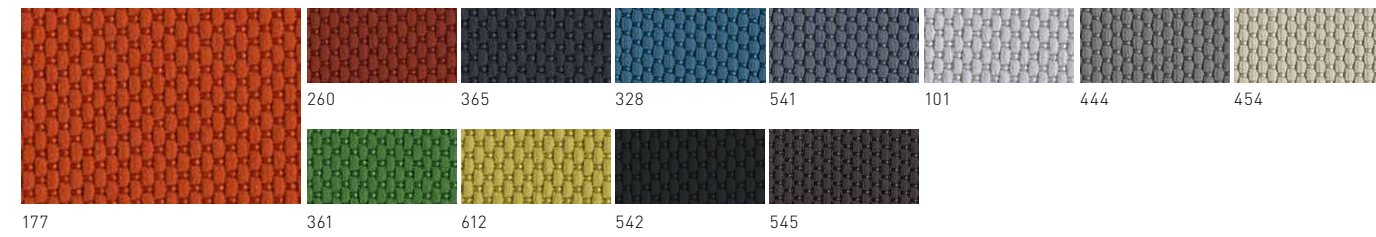

FOCUS / Category 1

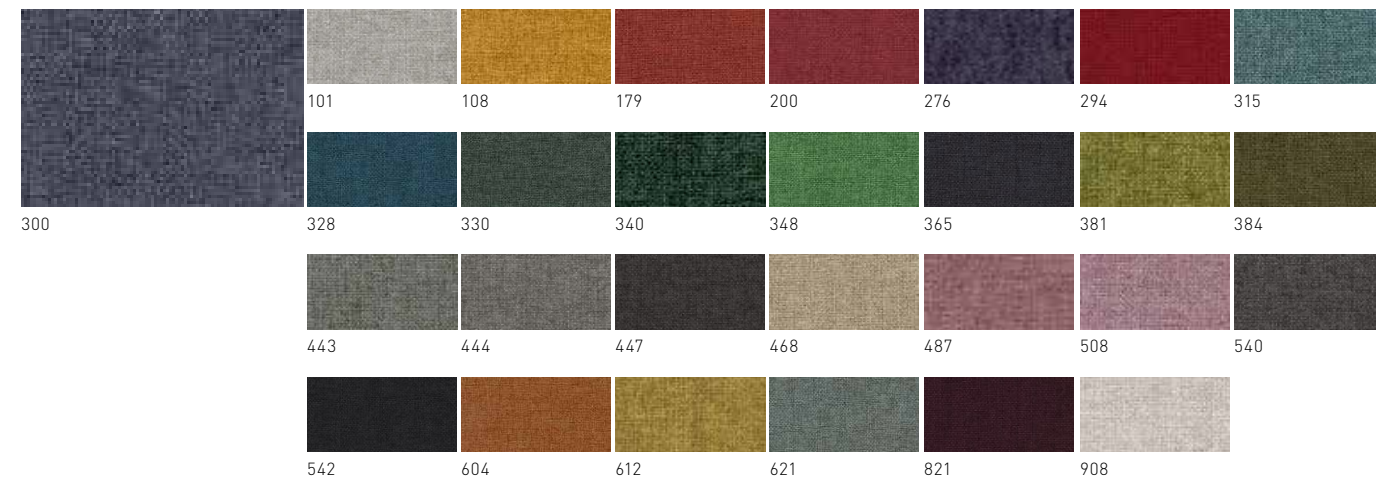

MESSENGER / Category 1

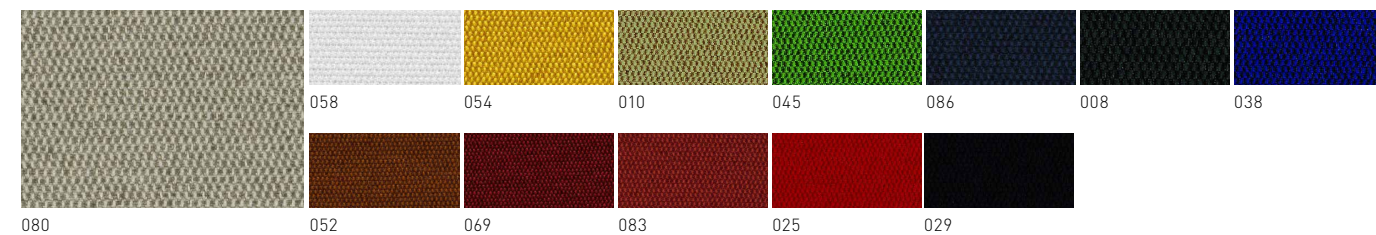

CATEGORY 2
Metric

CATEGORY 3
Atlas & Revive 1

METRIC / Category 2



ATLAS / Category 3

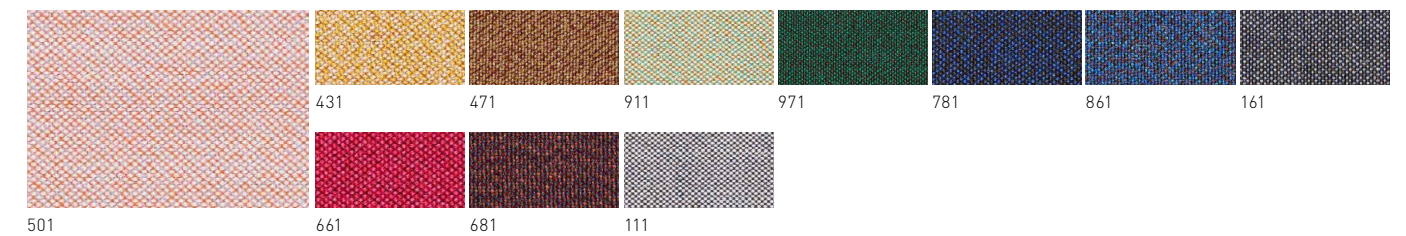

REVIVE 1 / Category 3

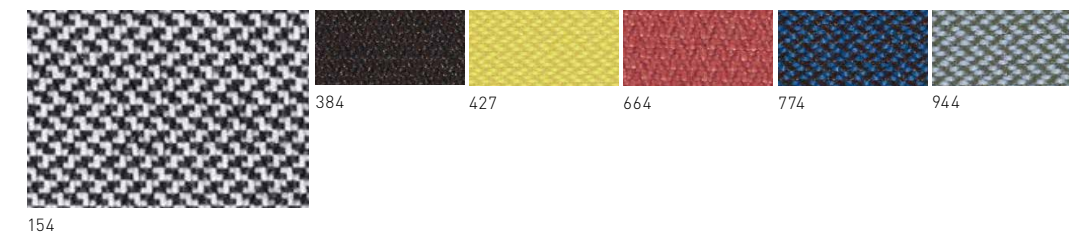



CATEGORY 4
Glow, Recheck,
Remix 3 & Rime

GLOW / Category 4

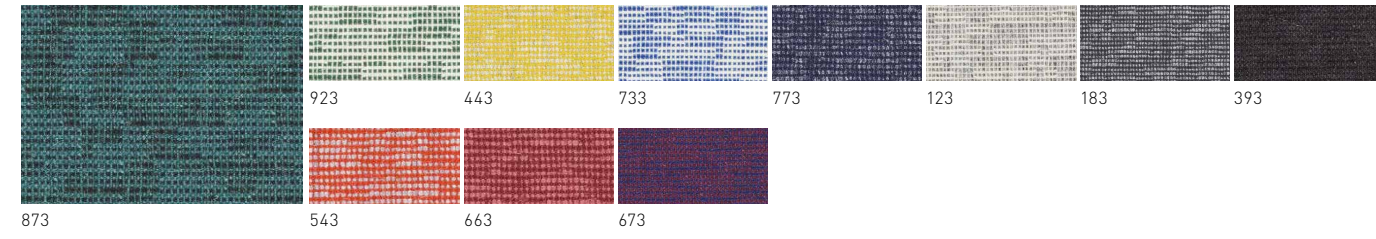

RECHECK / Category 4

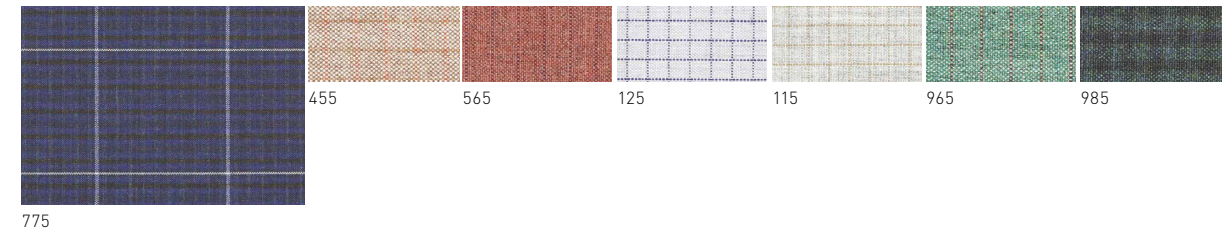

REMIX 3 / Category 4

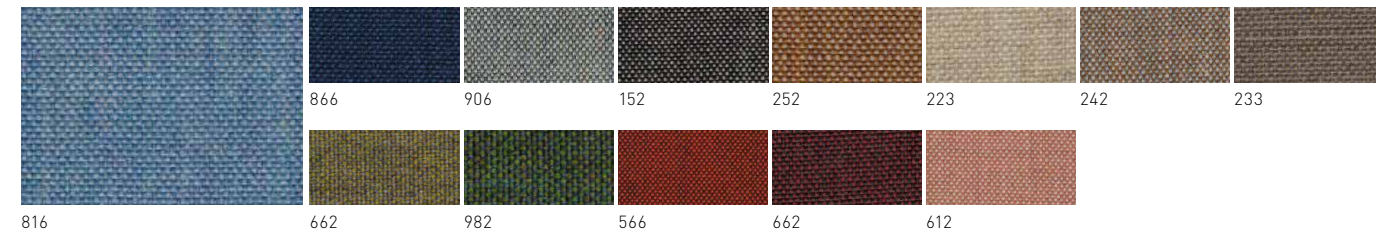

RIME / Category 4

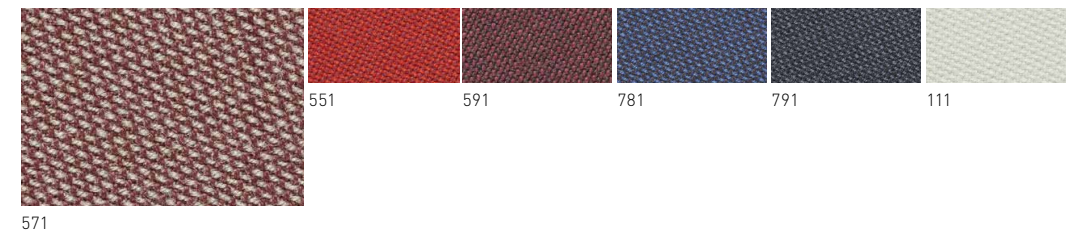

CATEGORY 5
Steelcut Trio 3
& Tonica 2

STEELCUT TRIO 3 / Category 5



TONICA 2 / Category 5

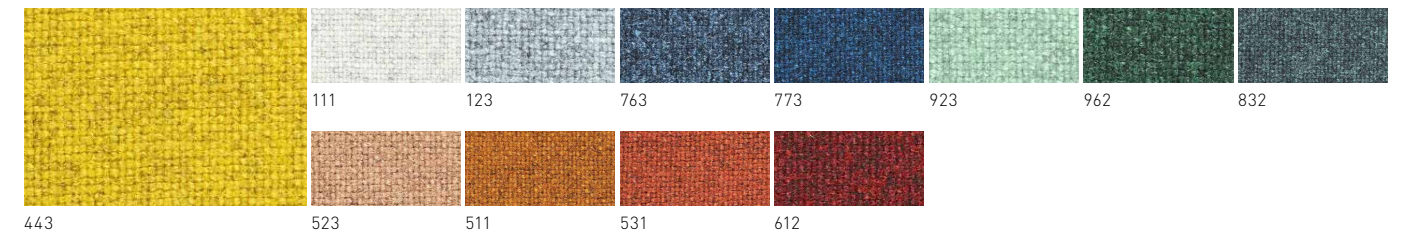

HEALTHCARE
FABRIC



CATEGORY 1.5

Silk

CATEGORY 2

Rave

CATEGORY 2.5

Trieste

SILK / Category 1.5

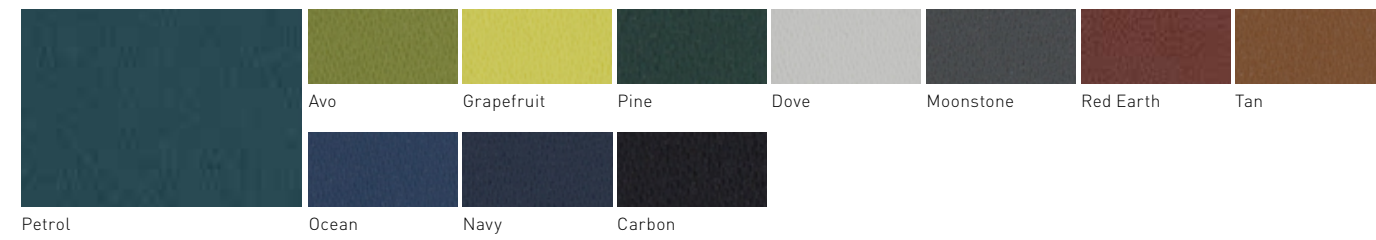

RAVE / Category 2



TRIESTE / Category 2.5

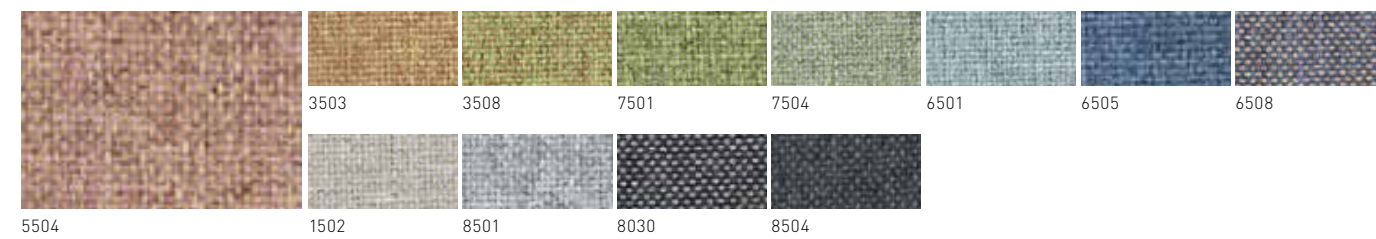

LEATHER



CATEGORY 2

Metador,

CATEGORY 3

Medici

CATEGORY 4

Heirloom

METADOR / Category 2



MEDICI / Category 3



HEIRLOOM / Category 4

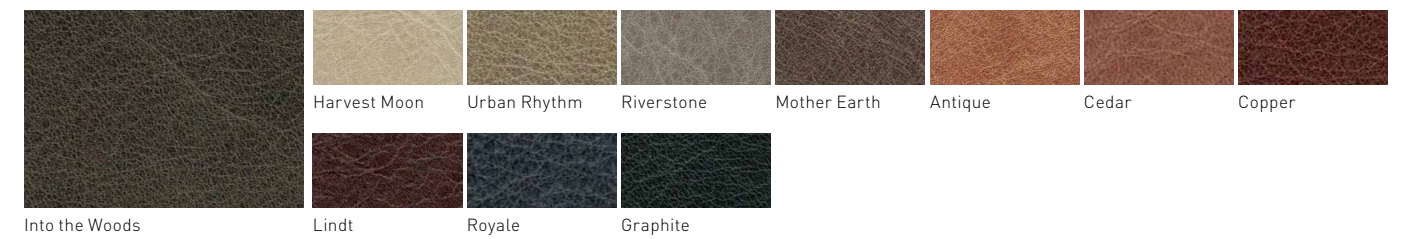





Ecology and sustainability

Schiavello's most important commitment to sustainability is the company-wide Environmental Management System under ISO 14001. The environmental design principles realised means we design for the environment, focusing on efficient energy use and minimum emissions, longevity and durability, re-use and recycling of our products.

Our principles of ME WE (Materials, Energy, Waste Emissions) give us a simple way to think how our operations impact the environment.

Printed on an Australian made paper stock that is PEFC Certified and made from elemental chlorine free bleached pulp sourced from sustainably managed forests and non-controversial sources. It is manufactured by an ISO 14001 certified mill using renewable energy sources.



FS 604920

EMS 604919

About Schiavello

Schiavello is a multi-disciplinary company dedicated to developing intelligent, inspiring, ecological and resilient solutions for the office, the home and public spaces.

Schiavello's concepts and products are developed in Australia by applying a design process that brings together the company's core design principles and engineering with the creativity of local and international designers.

The Schiavello Head Office and manufacturing facilities are integral elements of the Schiavello Philosophy. They provide the opportunity to develop a rich tapestry of knowledge that ultimately informs the right solutions and tools for an organisation and its people.

To find a Schiavello Showroom or partner in your area, please visit [schiavello.com/location](https://www.schiavello.com/location)

All intellectual property rights and copyrights are reserved. Nothing contained in this brochure may be reproduced without written permission. Schiavello Group Pty Ltd reserves the right to change any or all details without prior notice. All dimensions stated within this document are nominal and/or approximate only and subject to variation.

SCH/AKUS.0D-D