

KARO



schiaavello

IVAN WOODS

Schiavello and the late Ivan Woods shared a long history. Our collaborative design process, which evolved over many years, yielded distinctive collections such as the Kayt and Toro collections, Maui Chair, Bomba Sofa, Tango and many more.

Ivan enriched his designs' emotional qualities through fine detailing, influenced by a strong architectural sensibility and carefully considered geometry. The unique combination of individual and robust personalities in his products resulted in a unique outcome that lent his products to a diverse range of scenarios.

Ivan grew up in Australia and studied interior architecture in Perth. Throughout his 30 years of designing interiors and products, he created work for the Langham and Marriott Hotels as well as international projects spanning the UK, US, Germany and Italy.





Introducing Karo

Karo is an ottoman range, designed by revered Australian designer Ivan Woods for Schiavello. Karo's profile is elegant and sculptural, suited to both living and working environments.

OTTOMANS

The early ottoman can be traced back to the Turkish Ottoman Empire and was designed as a low, wooden platform consisting of cushions.

Reflecting its Turkish roots, the later ottoman designs shared similar characteristics to bales of cotton that carpet weavers used to put their feet up.





INVITING

Karo's gentle, tapered edges and soft upholstery encourage warmth to the space it resides within.

COMFORT

Tapered edges allow for a comfortable seated position, while a high grade foam has been selected to support short to medium-term use while still focusing on absolute seating comfort.





VERSATILE

Available in a variety of small and generous sizes, as well as high and low options, Karo can cater to a variety of seating needs. Combine high and low Karos to create amphitheatre-style seating, seating with low barriers for privacy, or couch-style seating. Offering diversity in function, Karo can also simply be used as casual seating or a coffee table.

Available in a variety of fabrics and leathers, it can be a complementary addition to any interior, including the home, public spaces, or breakout areas in the office.



RETREAT

Karo is for private moments – a temporary seat while you take a phone call or write a quick email...

Karo



11 — 12

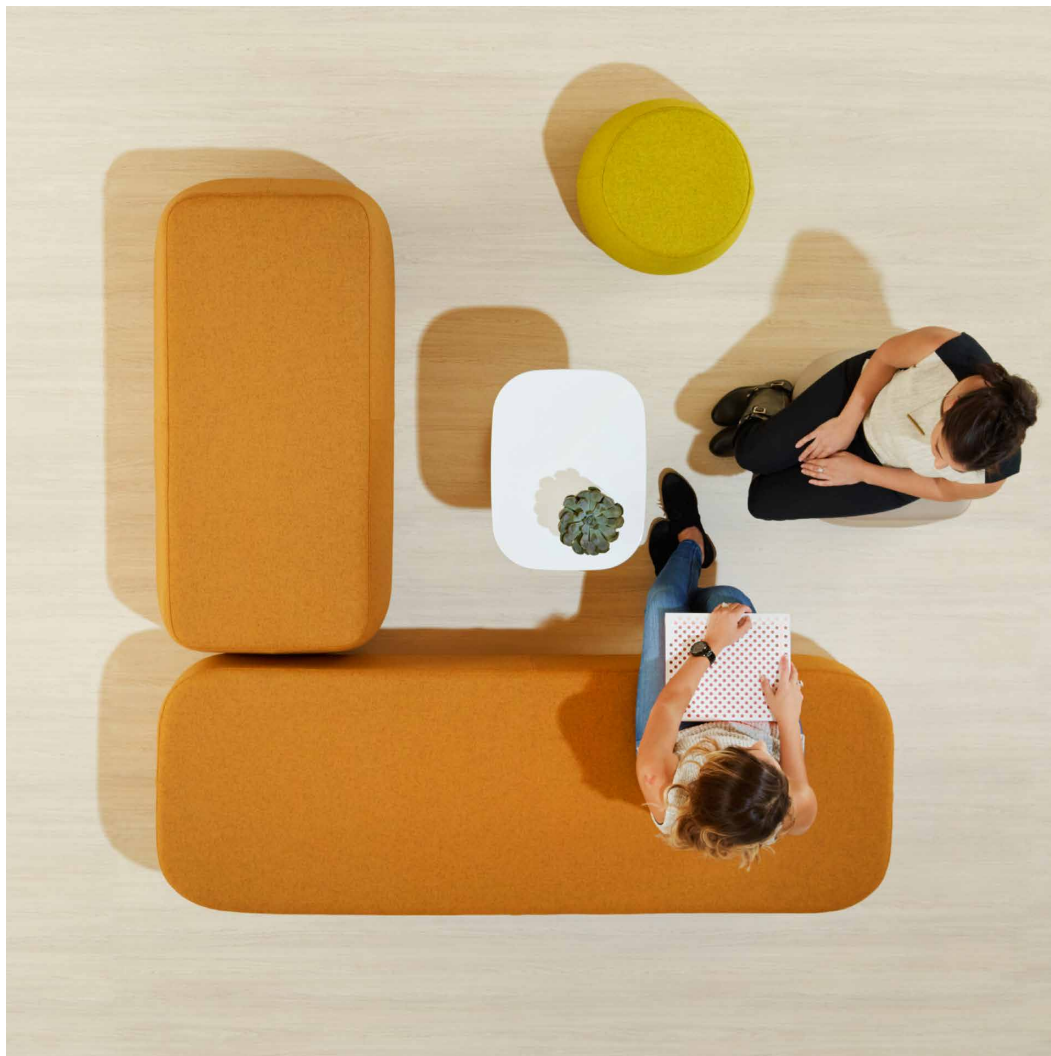

COLLABORATE

...Or use it for impromptu catch-ups, casual meetings or flexible seating.

MOBILITY

Karo's lightweight form enables it to easily be moved around and reconfigured – the perfect addition to ABW and agile workspaces as it allows employees to create the space they need.

Karo



13 — 14

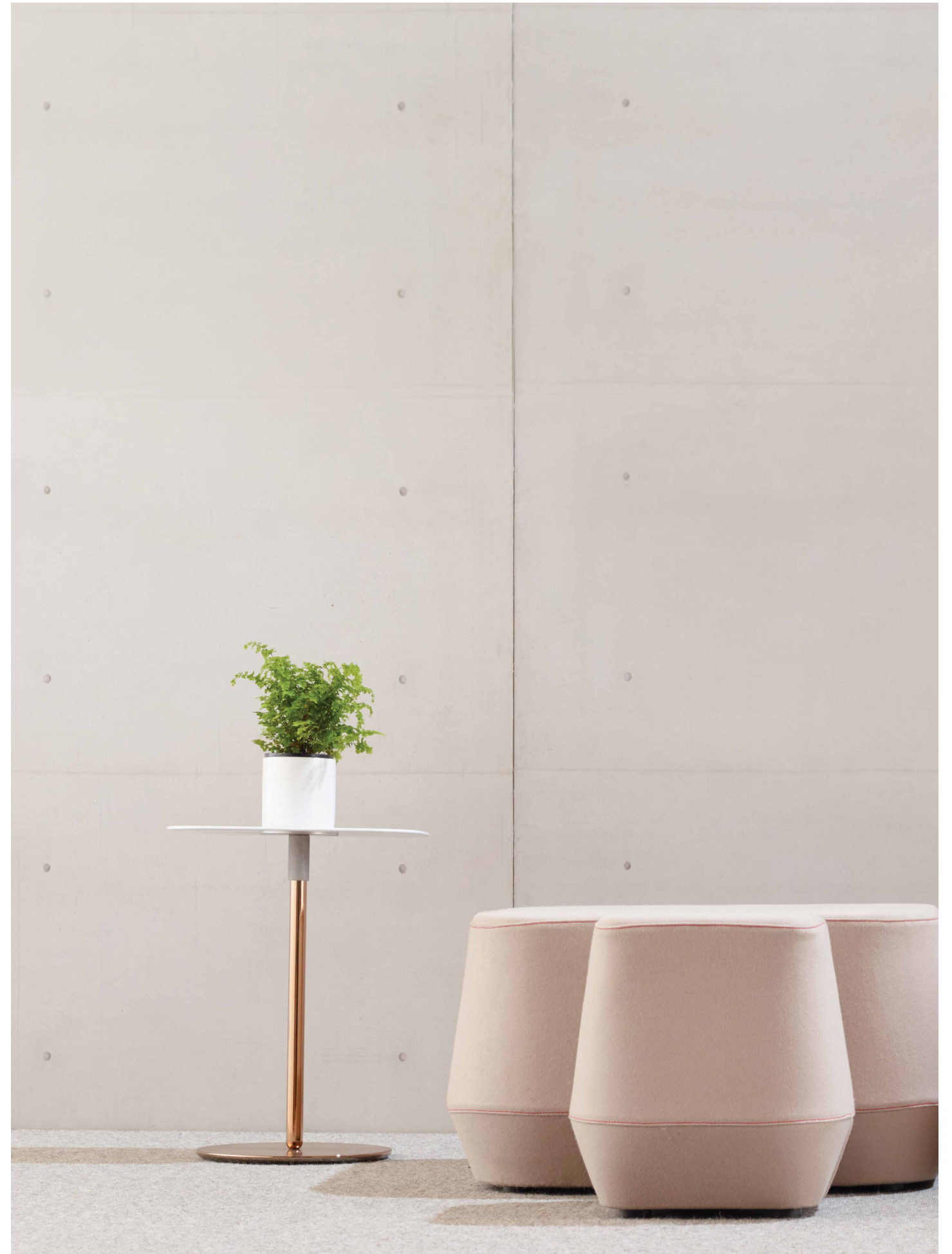

Measurements

Karo is available in round, square and rectangle shapes, in a high and low heights, and in a variety of sizes and profiles.

Round chamfered edge / 450 Dia

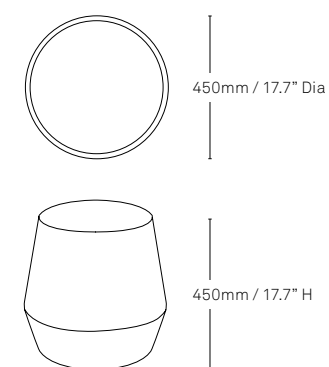

Round straight edge / 450 Dia

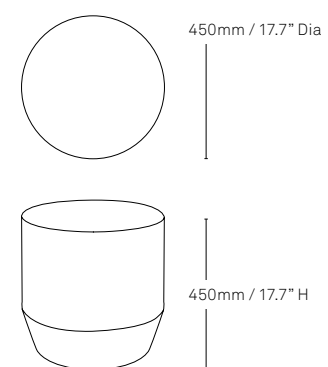

Round chamfered edge / 600 Dia

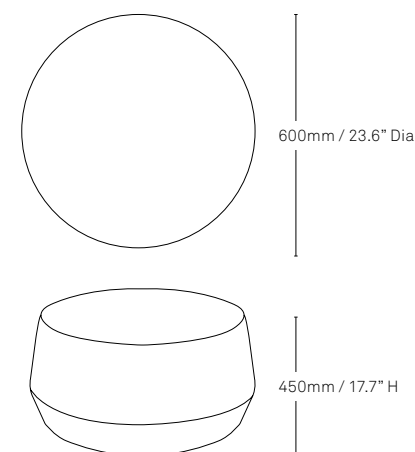

Round straight edge / 600 Dia

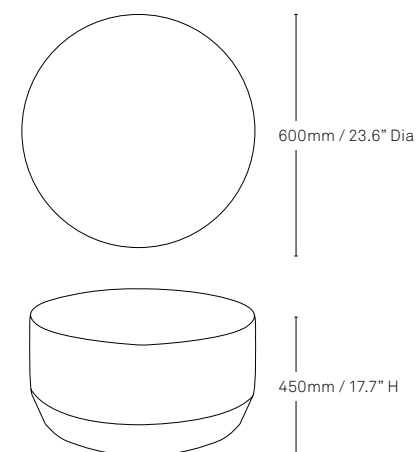

Round chamfered edge / 900 Dia

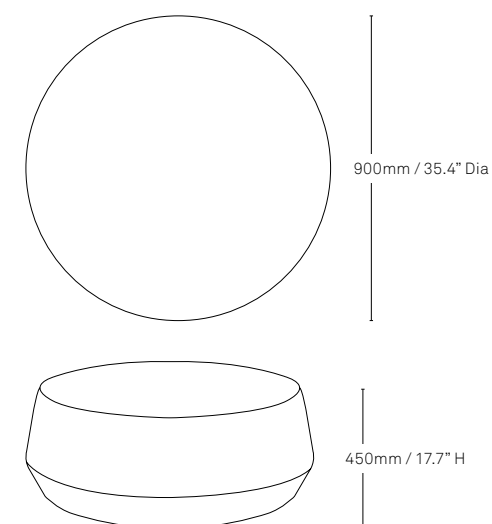

Round straight edge / 900 Dia

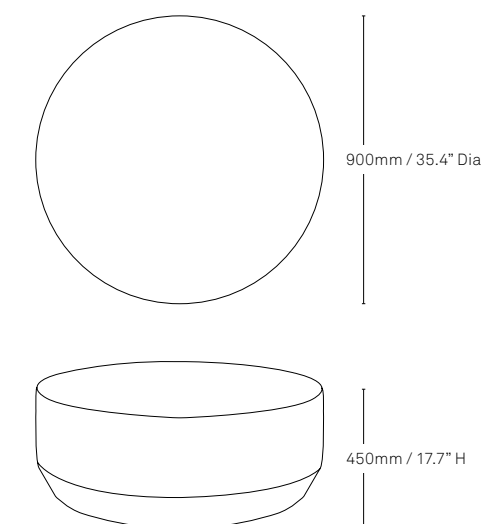

Round chamfered edge / 1200 Dia

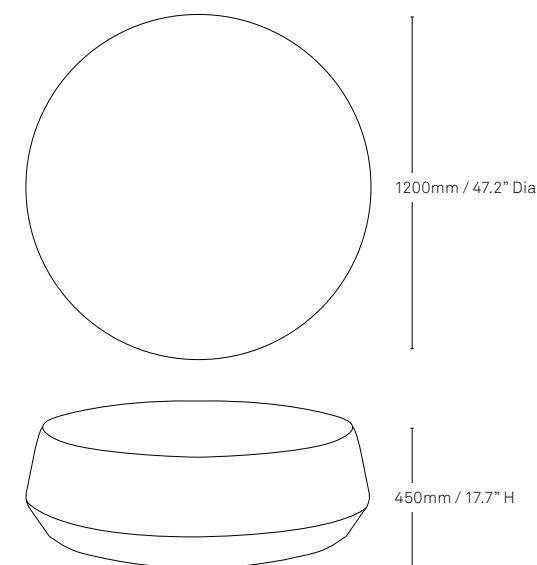

Round straight edge / 1200 Dia

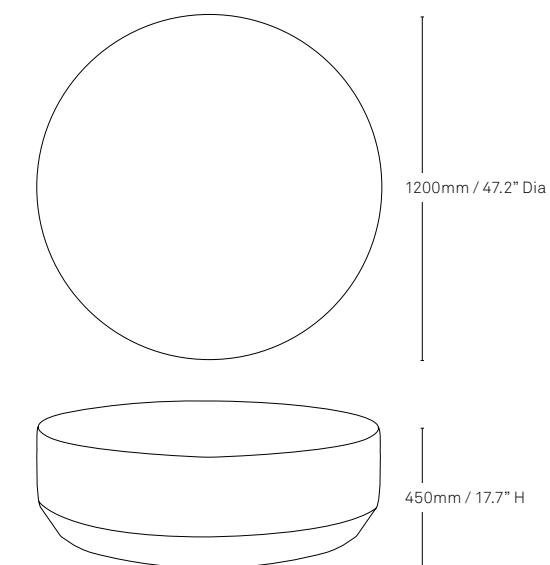

Square chamfered edge / 450 D

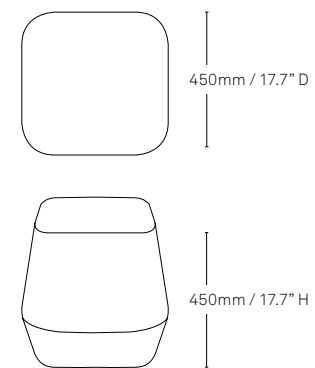

Square straight edge / 450 D

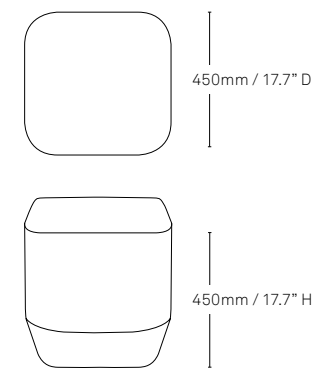

Square chamfered edge / 900 D

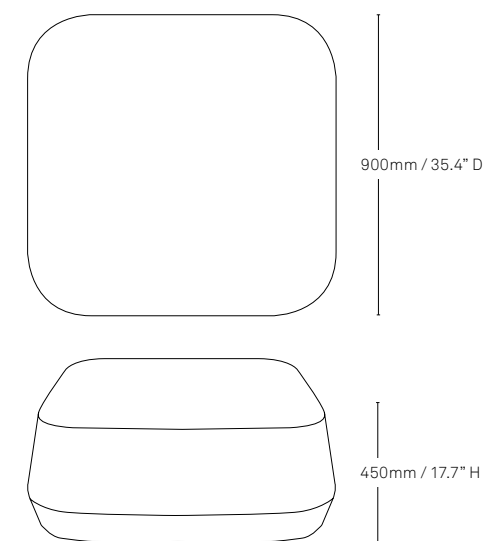

Square straight edge / 900 D

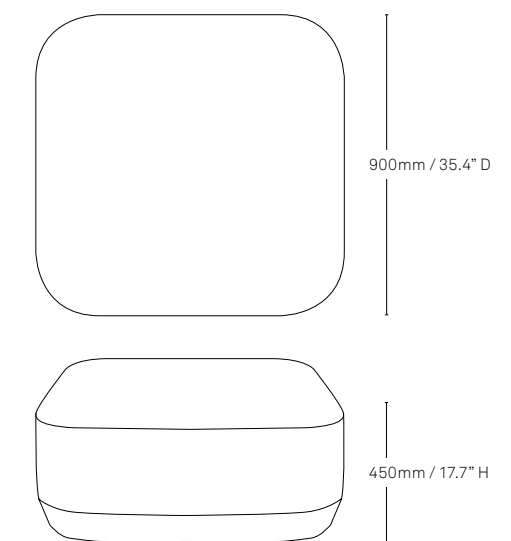

Square chamfered edge / 600 D

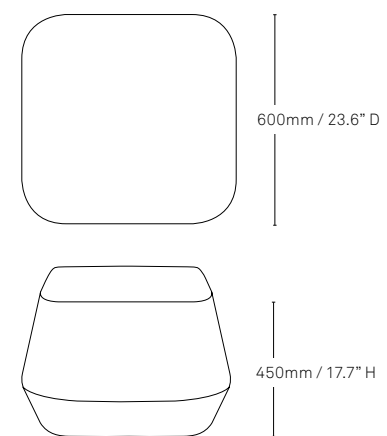

Square straight edge / 600 D

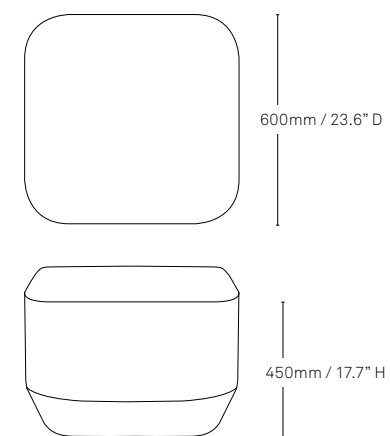

Square chamfered edge / 1200 D

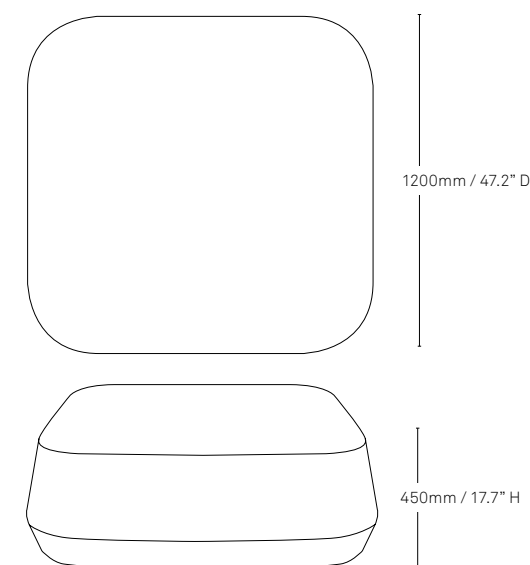

Square straight edge / 1200 D

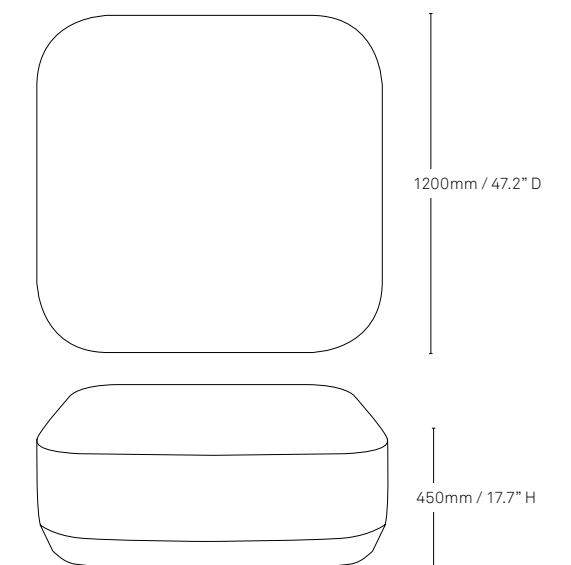

Rectangle chamfered edge / 1500 W

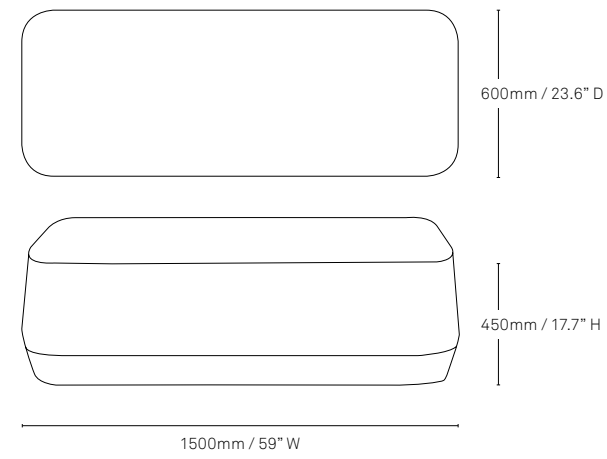

Rectangle straight edge / 1500 W

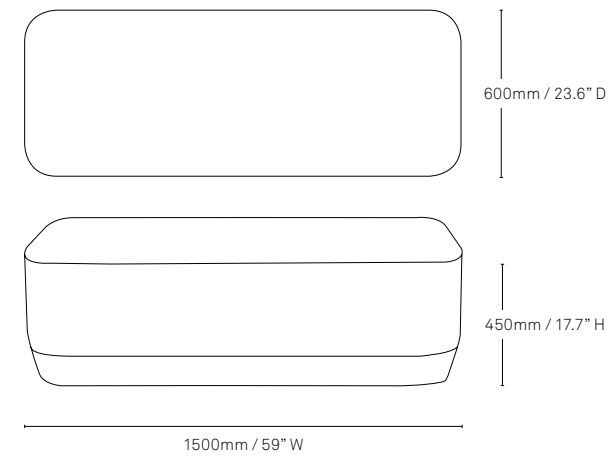

Rectangle high straight edge / 1500 W

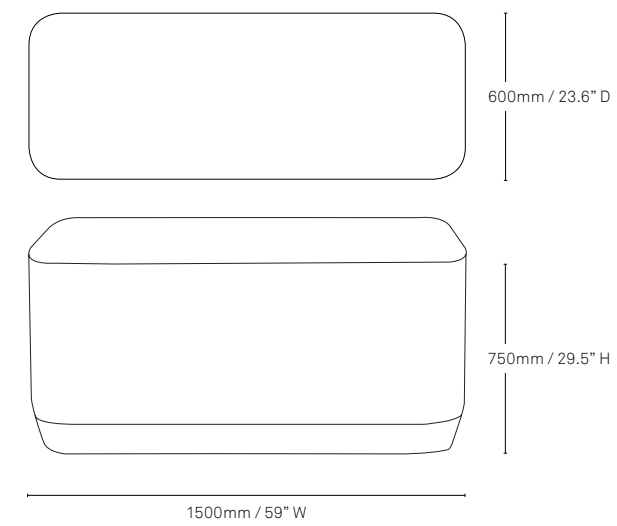

Rectangle high straight edge / 1800 W

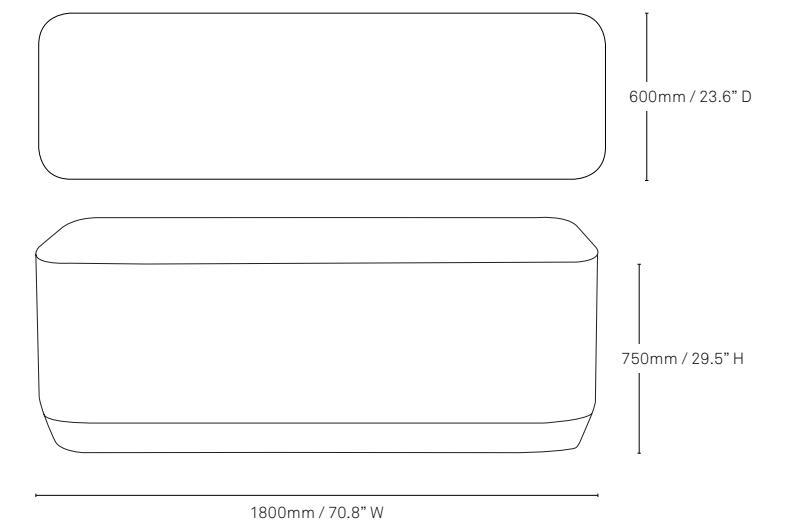

Rectangle chamfered edge / 1800 W

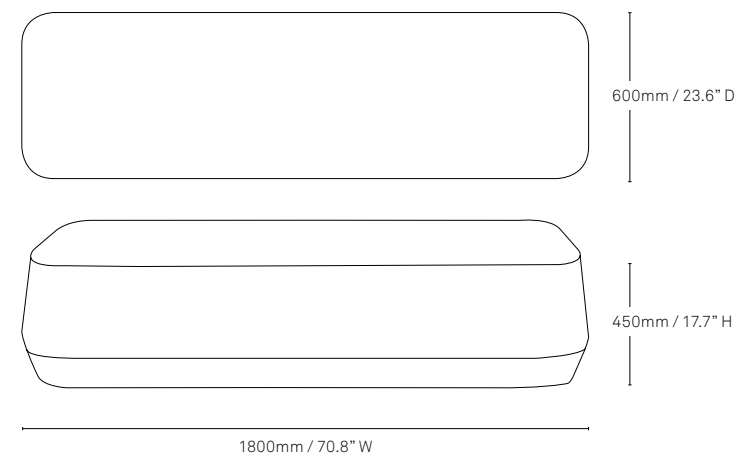

Rectangle straight edge / 1800 W

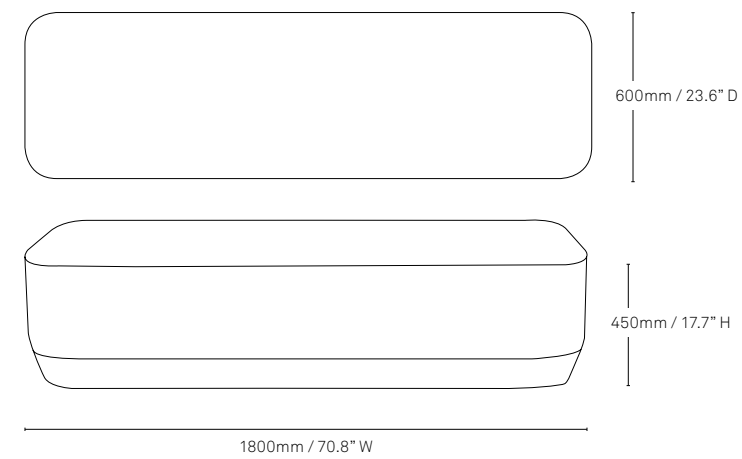

Rectangle high straight edge / 1500 W

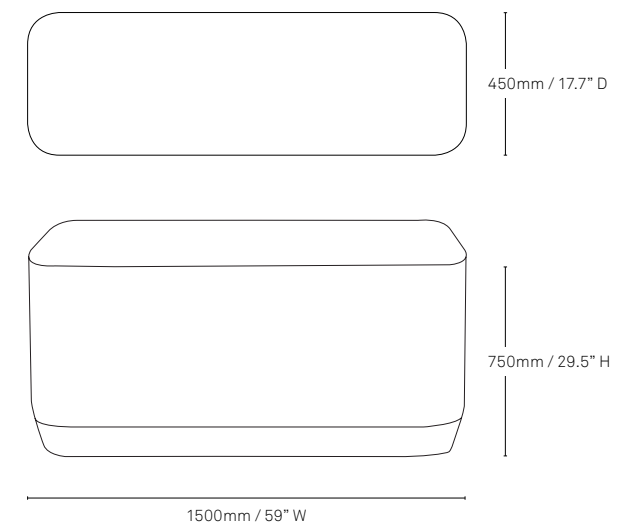

Rectangle high straight edge / 1800 W

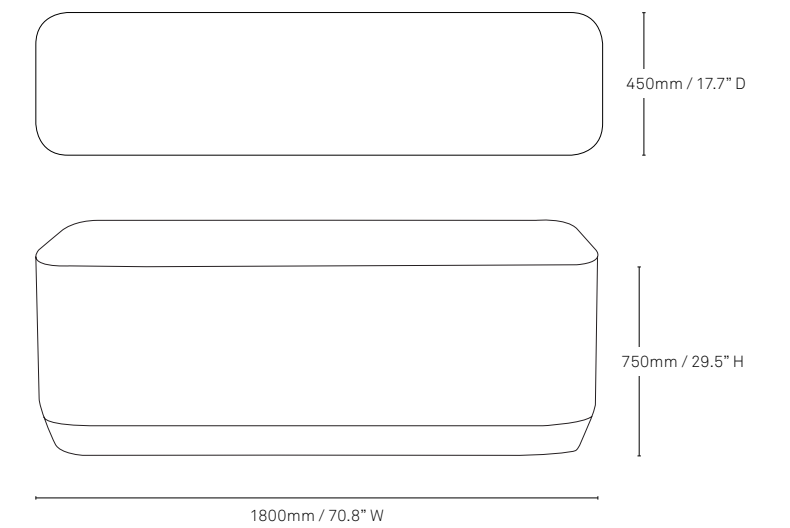

Left L-shape low straight edge / 1200 W

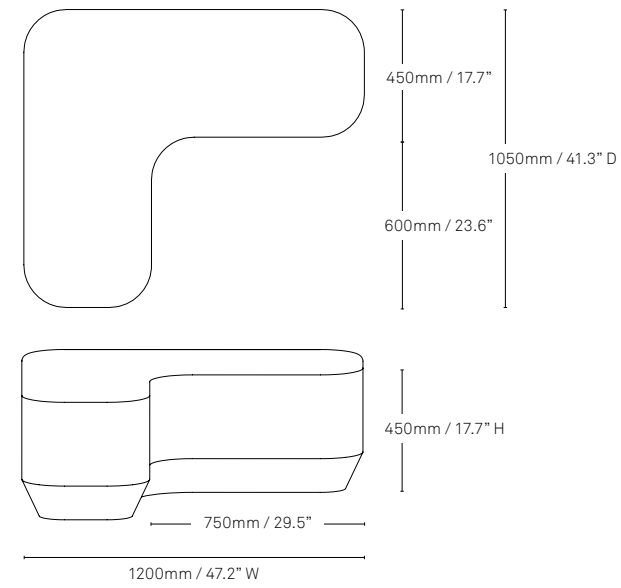

Left L-shape low straight edge / 1350 W

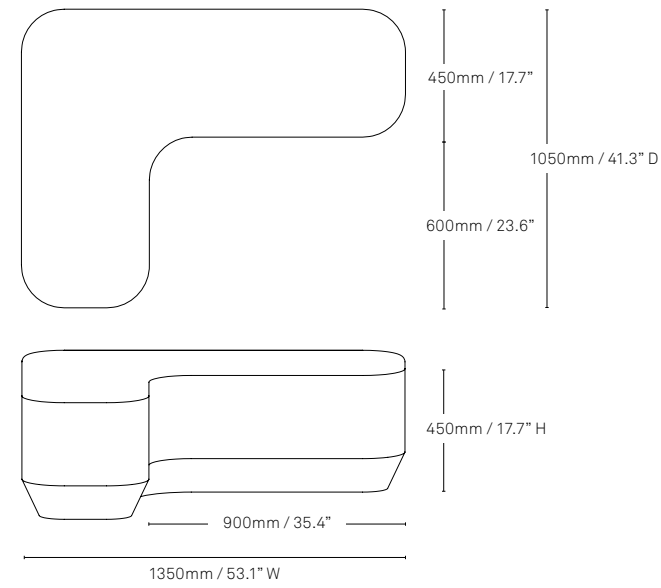

Right L-shape low straight edge / 1200 W

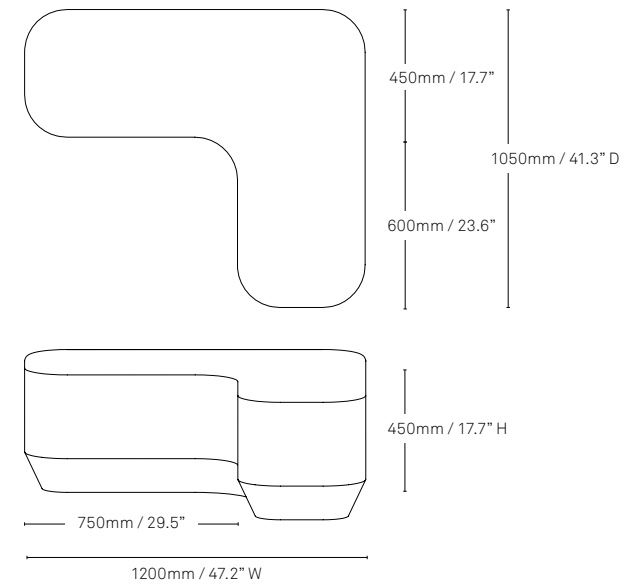

Right L-shape low straight edge / 1350 W

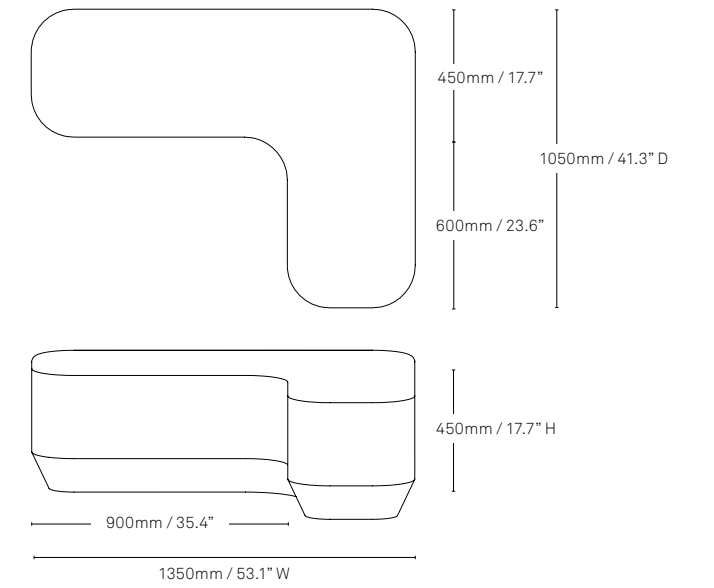

Left L-shape high straight edge / 1200 W

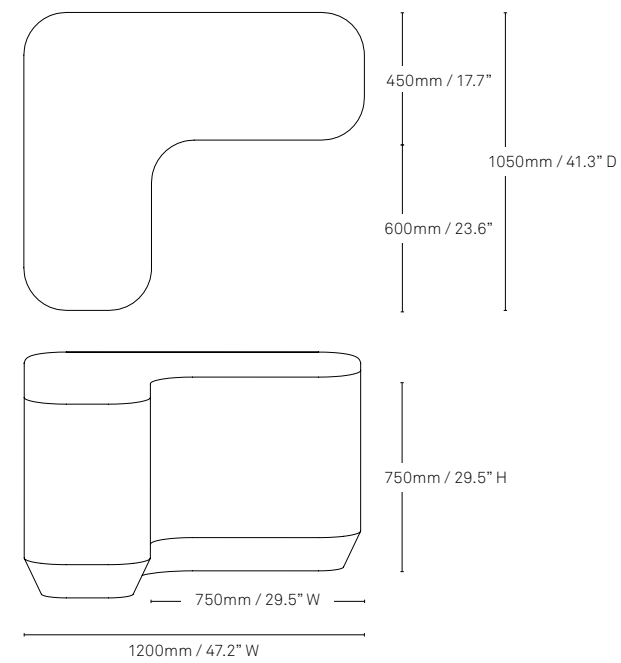

Left L-shape high straight edge / 1350 W

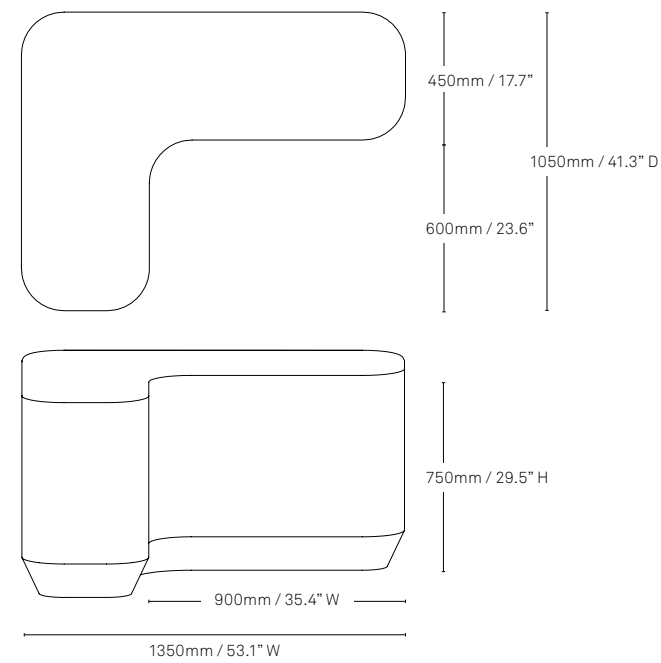

Right L-shape high straight edge / 1200 W

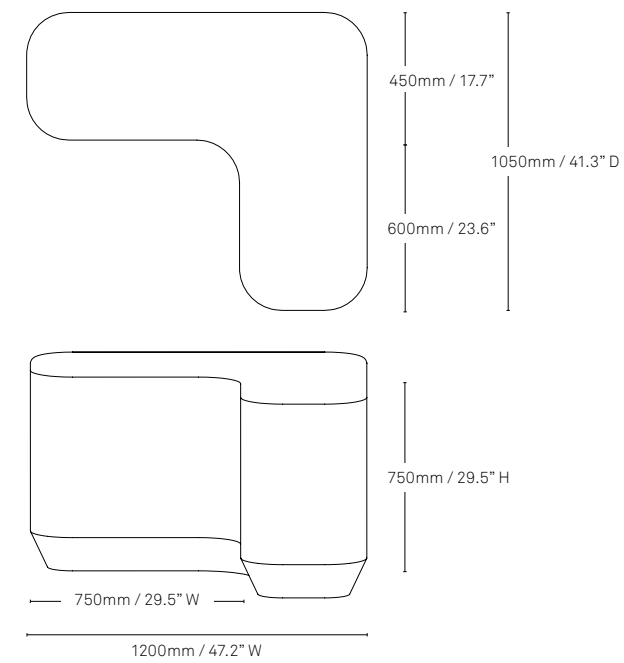

Right L-shape high straight edge / 1350 W

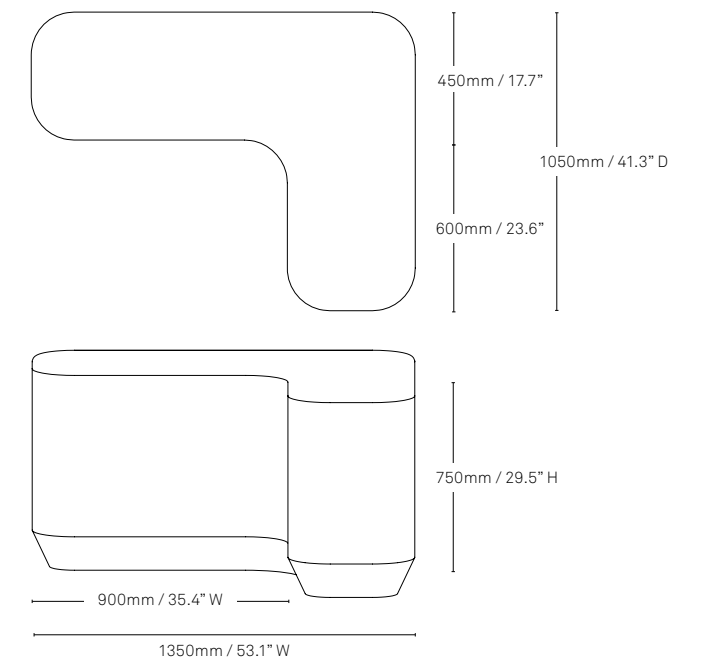

Corner low straight edge / 1200 W

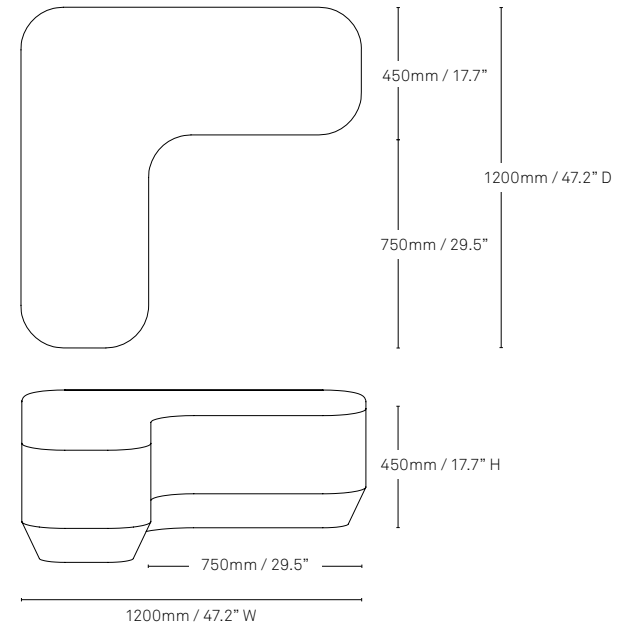

Corner low straight edge / 1350 W

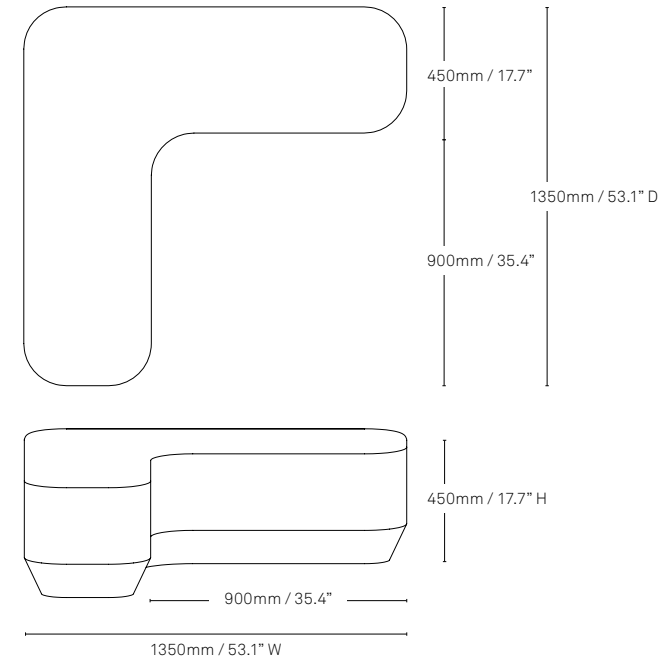

T-shape high straight edge / 1950 W

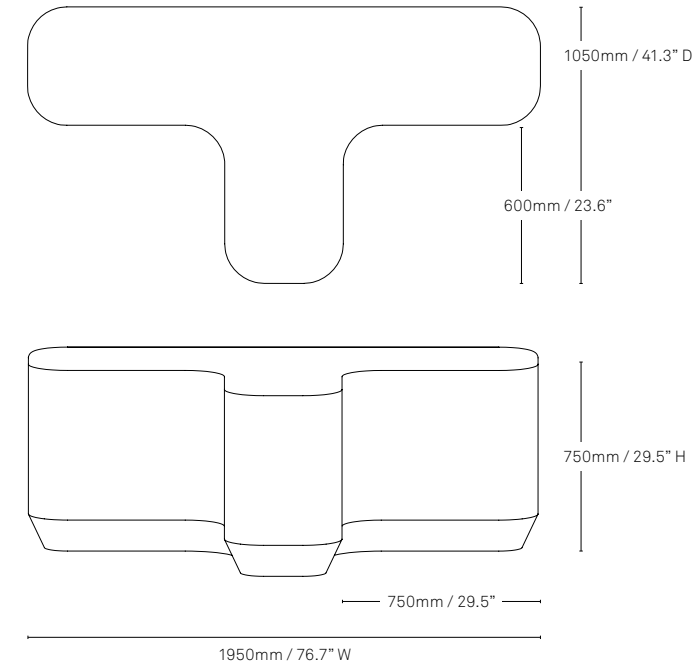

T-shape high straight edge / 2250 W

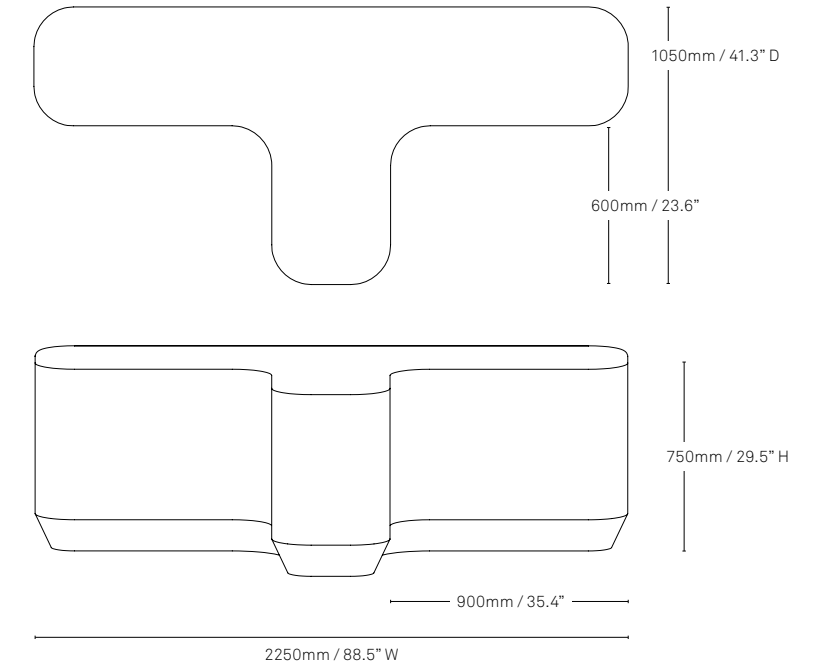

Corner high straight edge / 1200 W

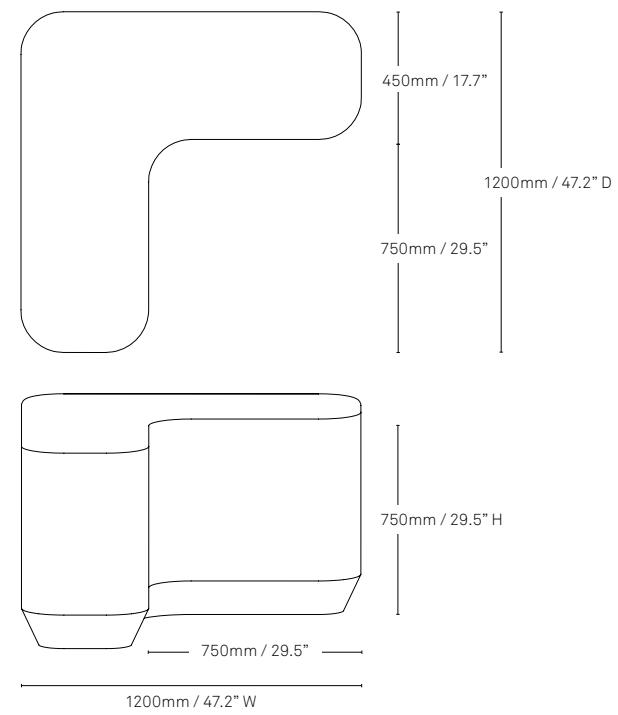

Corner high straight edge / 1350 W

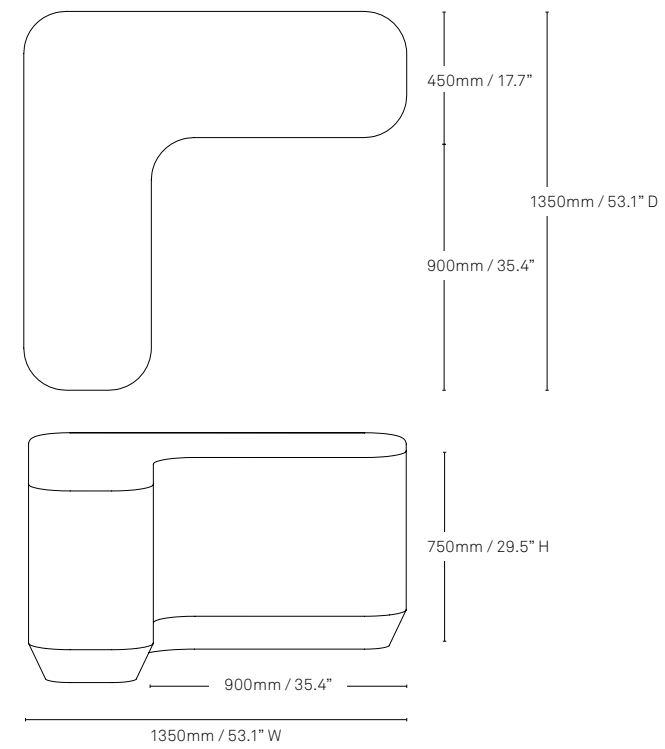

ColourLab

Schiavello's innovative ColourLab brings a considered and cohesive palette of finishes to working and living spaces. Curated by Giulio Ridolfo and developed by Schiavello, the palette beautifully balances colour, texture and layering across a variety of materials.

CATEGORY 1
Edge, Focus
& Messenger

FABRIC

EDGE / Category 1

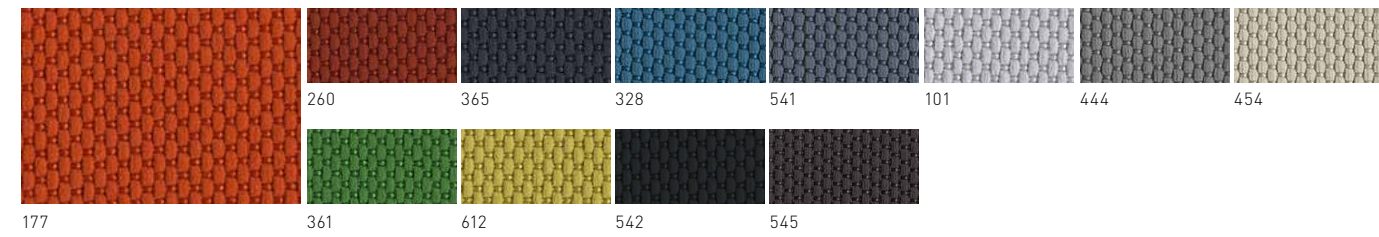

FOCUS / Category 1

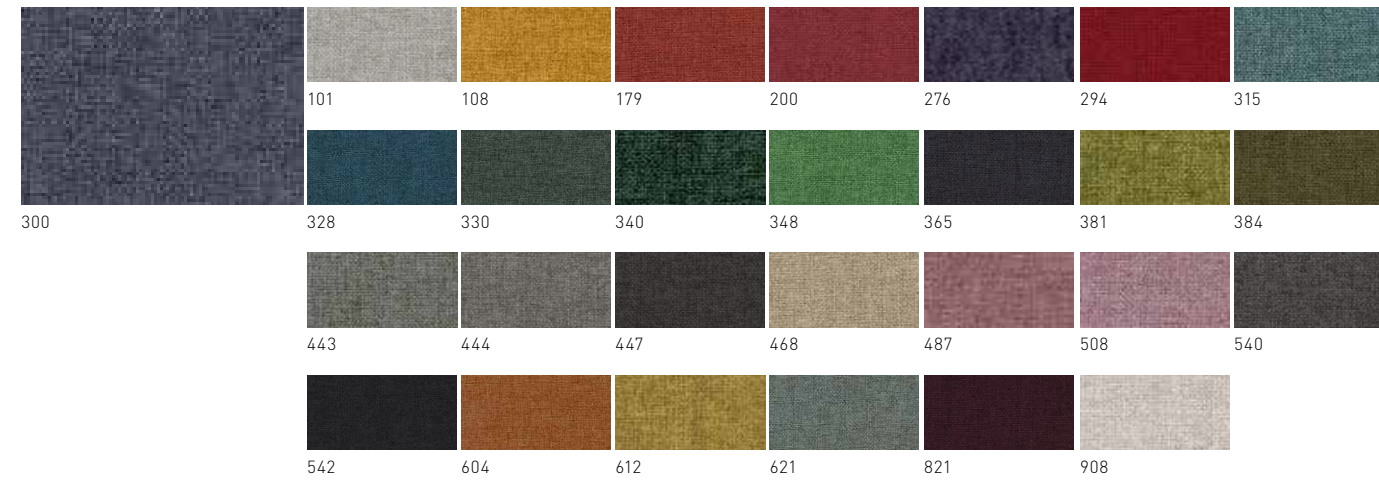

MESSENGER / Category 1



CATEGORY 2
Metric

CATEGORY 3
Atlas & Revive 1

METRIC / Category 2



ATLAS / Category 3

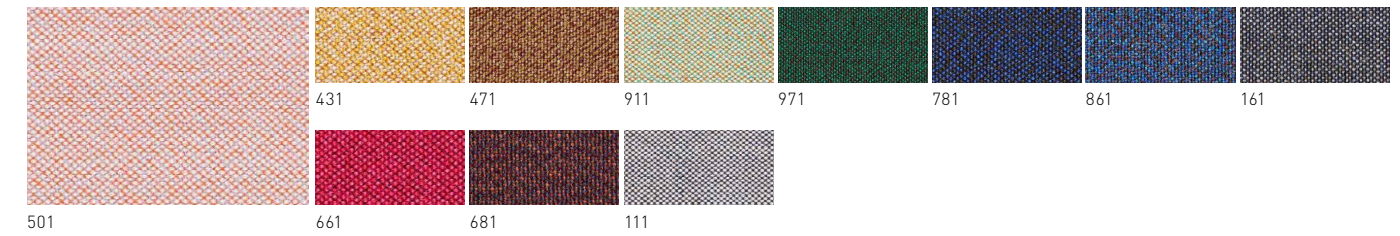

REVIVE 1 / Category 3

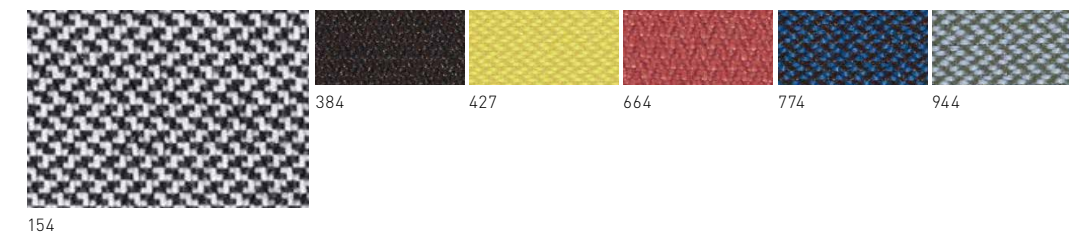



CATEGORY 4
Glow, Recheck,
Remix 3 & Rime

GLOW / Category 4

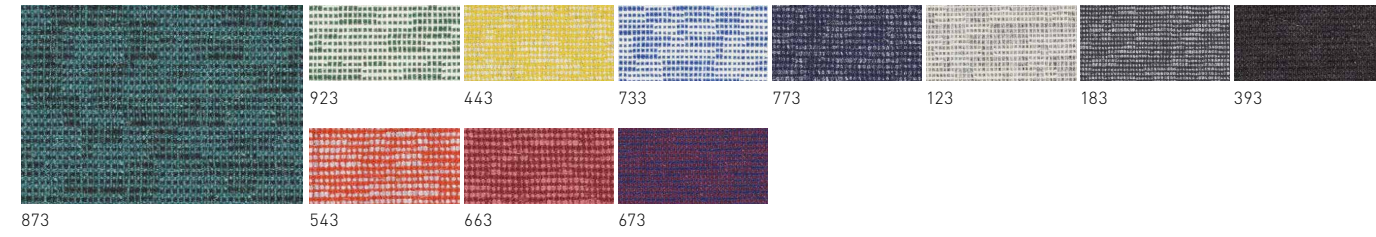

RECHECK / Category 4

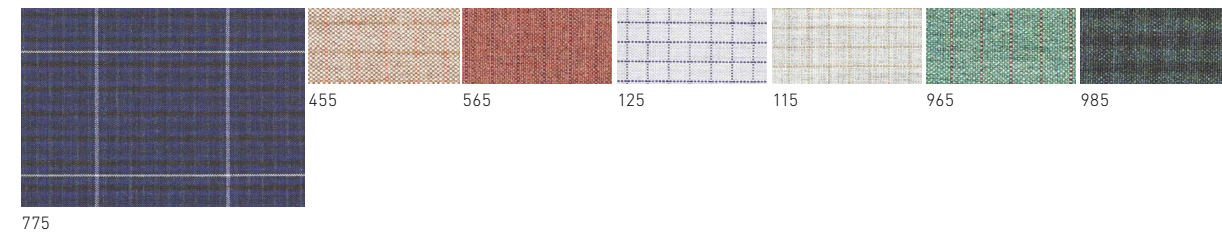

REMIX 3 / Category 4

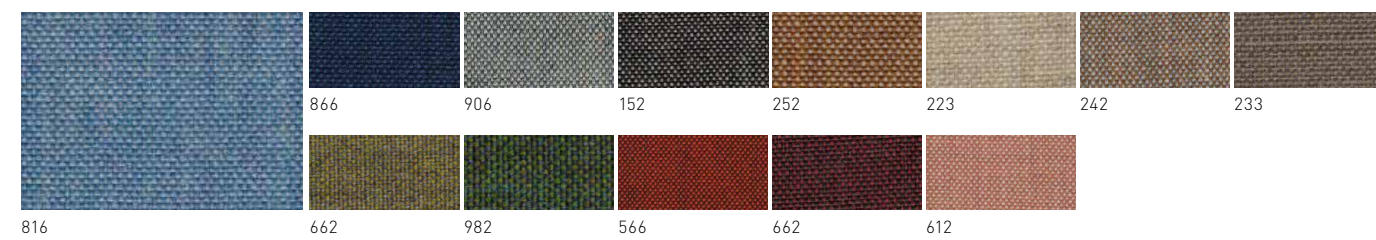

RIME / Category 4

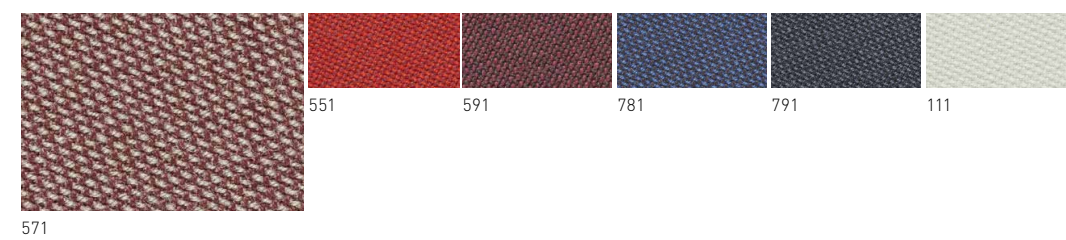

CATEGORY 5
Steelcut Trio 3
& Tonica 2

STEELCUT TRIO 3 / Category 5



TONICA 2 / Category 5

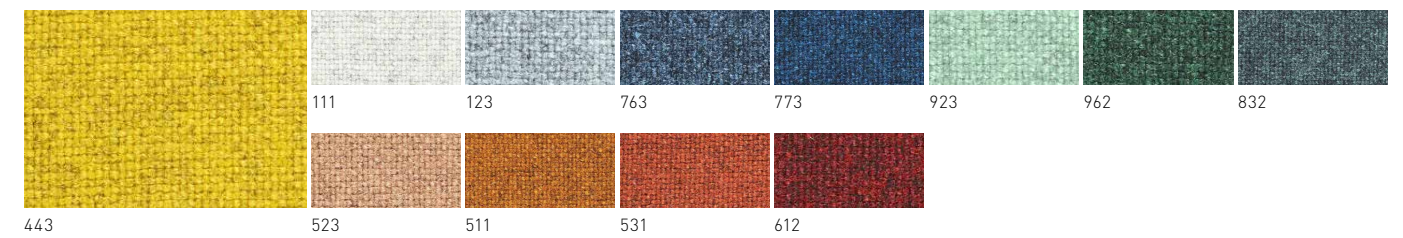

HEALTHCARE
FABRIC



CATEGORY 1.5

Silk

CATEGORY 2

Rave

CATEGORY 2.5

Trieste

SILK / Category 1.5

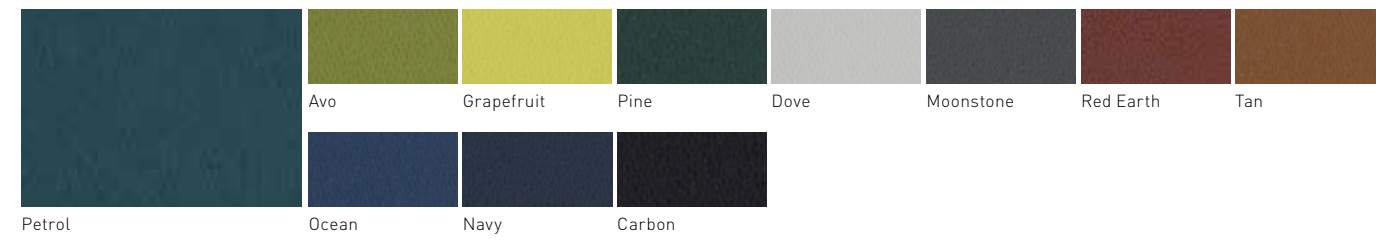

RAVE / Category 2



TRIESTE / Category 2.5

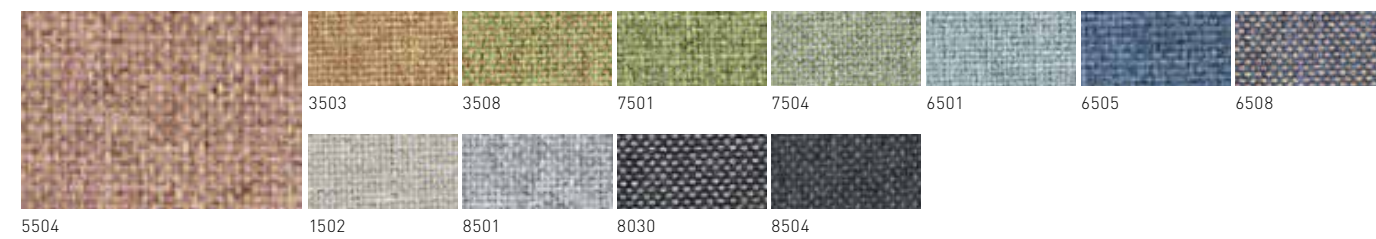

LEATHER



CATEGORY 2

Metador,

CATEGORY 3

Medici

CATEGORY 4

Heirloom

METADOR / Category 2



MEDICI / Category 3



HEIRLOOM / Category 4

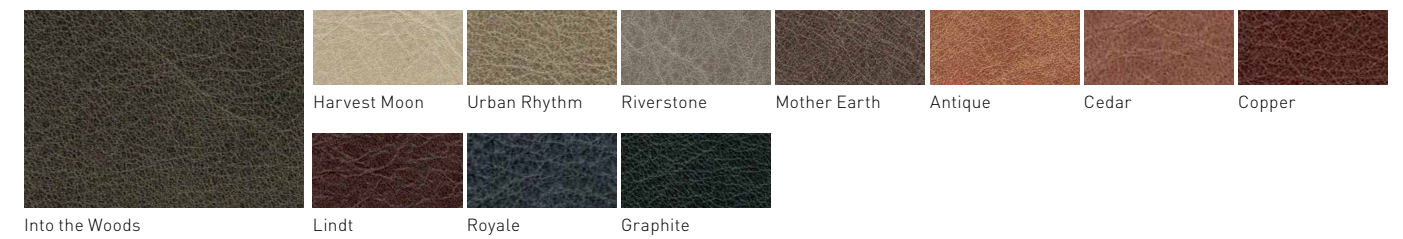



UNIFY

Karo combines geometric shapes with gentle, organic lines for an ottoman that blends effortlessly in a magnitude of fitouts, creating a punctuated, unified space.



Ecology and sustainability

Schiavello's most important commitment to sustainability is the company-wide Environmental Management System under ISO 14001. The environmental design principles realised mean we design for the environment, focusing on efficient energy use and minimum emissions, longevity and durability, re-use and recycling of our products.

Our principles of ME WE (Materials, Energy, Waste Emissions) give us a simple way to think about how our operations impact the environment.



Printed on an Australian made paper stock that is PEFC Certified and made from elemental chlorine-free bleached pulp sourced from sustainably managed forests and non-controversial sources. It is manufactured by an ISO 14001 certified mill using renewable energy sources.



FS 604920 EMS 604919

About Schiavello

Schiavello is a multi-disciplinary company dedicated to developing intelligent, inspiring, ecological and resilient solutions for the office, the home and public spaces.

Schiavello's concepts and products are developed in Australia by applying a design process that brings together the company's core design principles and engineering with the creativity of local and international designers.

The Schiavello head office and world-class manufacturing facilities are integral to our continually developing rich tapestry of knowledge. This knowledge ultimately assists us in informing the right solutions and tools for each organisation's needs and people, allowing us to consistently achieve our philosophy that 'Anything is possible'.

To find a Schiavello showroom or partner in your area, please visit [schiavellofurniture.com/find-us](https://www.schiavellofurniture.com/find-us)

All intellectual property rights and copyrights are reserved. Nothing contained in this brochure may be reproduced without written permission. Schiavello Group Pty Ltd reserves the right to change any or all details without prior notice. All dimensions stated within this document are nominal and/or approximate only and subject to variation.

SCH/C52.0D-F

A soft and relaxed ottoman, designed by Ivan
Woods for Schiavello.

www.schiavellofurniture.com/karo-ottoman

schiavello