

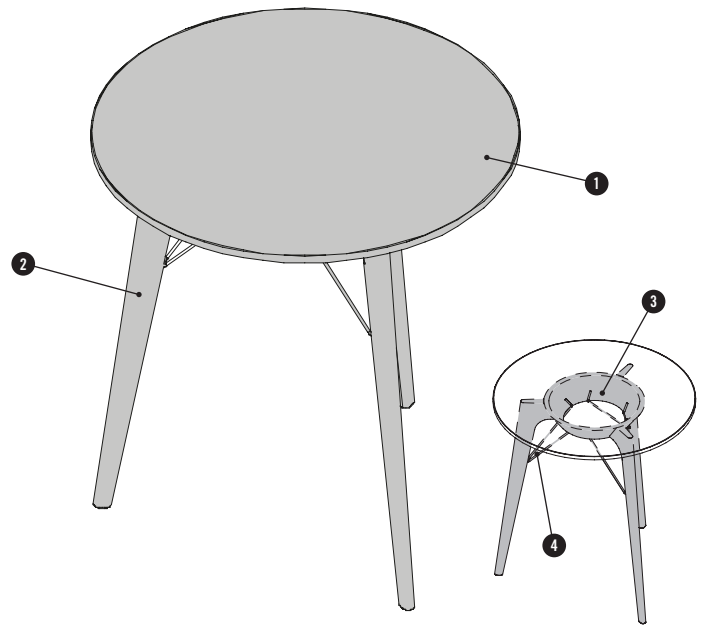

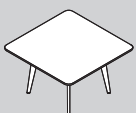

## PRODUCT DESCRIPTION

- ❶ **Tabletop:** 19 mm chipboard with melamine surface, 25 mm MDF board with chamfered edge, veneer or powder-coated, compact tabletop 13 mm with melamine surface.
- ❷ **Table legs:** Solid oak. Can be height adjusted  $\pm 5$  mm using the adjustment leg. The table legs are screwed to a frame made from plywood and together form the base.
- ❸ **Frame:** Plywood, varnished in platinum or anthracite.
- ❹ **Struts:** Steel struts lend the TIMBA Table high additional stability. Powder coated, white or black

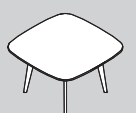
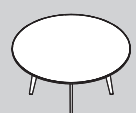

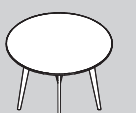
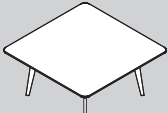
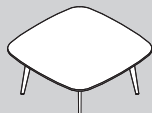
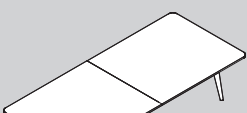
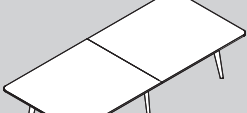
## OVERVIEW & DIMENSIONS

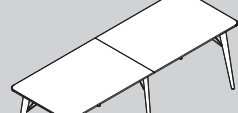
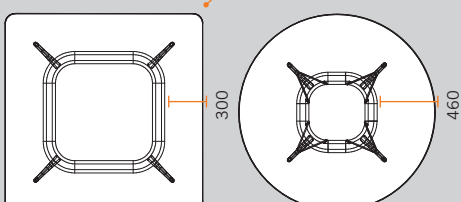
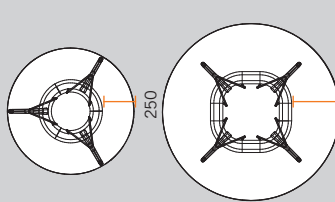
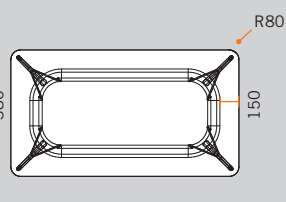
<p><b>TIMBA TABLE square</b></p> <p>height: 740 W x D</p>  <p>1.240x1.240</p>  <p>1.240x1.240</p>  <p>Ø 1.560</p>	<p><b>TIMBA TABLE HIGH round</b></p> <p>height: 1.070 W x D</p>  <p>Ø 1.000</p>  <p>Ø 1.400</p>
<p><b>rectangular</b></p>  <p>1.560x1.560</p>  <p>1.560x1.560</p>  <p>2.400x1.400</p>  <p>3.200x1.400</p>	<p><b>rectangular</b></p>  <p>1.800x1.000</p>  <p>3.200x1.100</p>
<p><b>square, soft square, rectangular</b></p> <p>height: 740</p> 	<p><b>round</b>      <b>round</b>      <b>rectangular</b></p> <p>height: 1.070</p>  

**Dimensions in mm**

## OPTIONS

### POWER BOWL

The Power Bowl consists of a plastic deep-set cup and a Turn Table. The cup (SZ black) is integrated into the tabletop and fitted with a connection plug board. It can be accessed easily by simply pushing the Turn Table away.

Possible shapes: oval or round, depending on table height and tabletop shape. Position: centred, left and right if the tabletop is split.

Turn Table made of solid oak or MDF powder-coated in white or anthracite.

Dimensions of Turn Table oval: 405x228 mm  
Dimensions of Turn Table round: Diameter: 450 mm

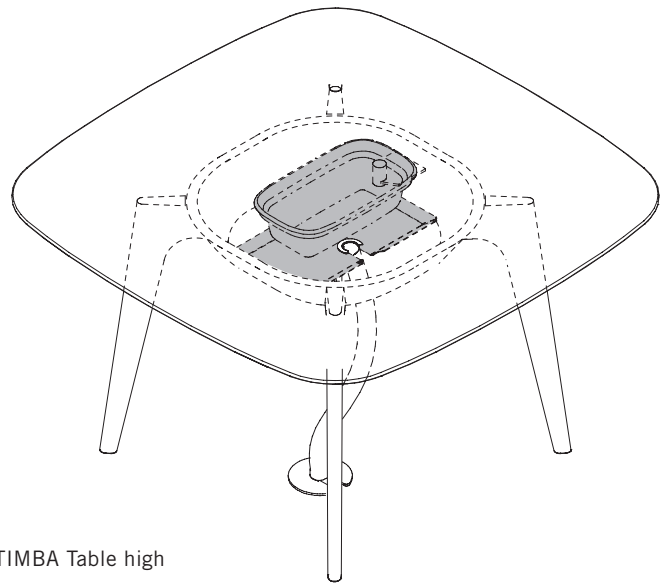

TIMBA Table

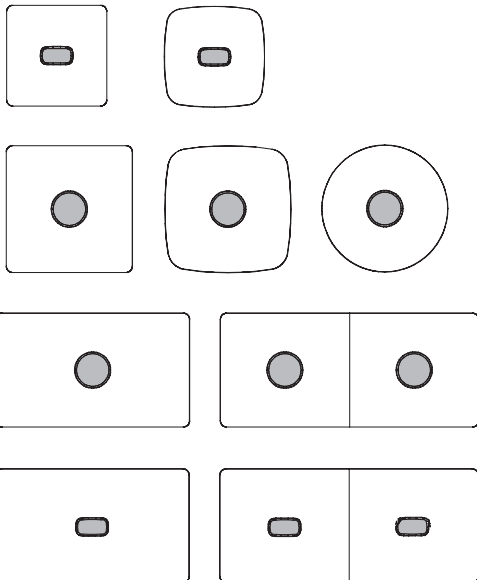

TIMBA Table high

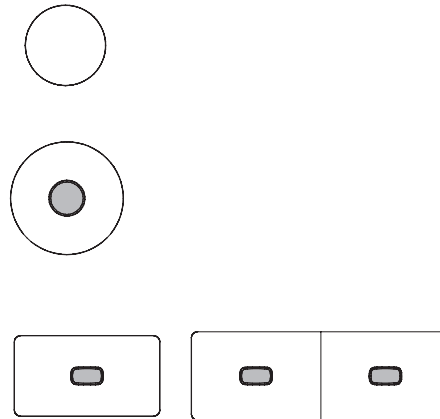

### MESH TUBE

A mesh tube can be ordered as an optional accessory for the Power Bowl. It is hooked into the Power Bowl Cup and is used to vertically organise the cables.

Material & colour: Mesh tube made of mesh fabric in black, base plate made of steel powder-coated in black.

Length for a sitting height table: 660 mm  
Length for a standing height table: 1.060 mm  
Mesh tube diameter: 43 mm  
Base plate diameter: 146 mm

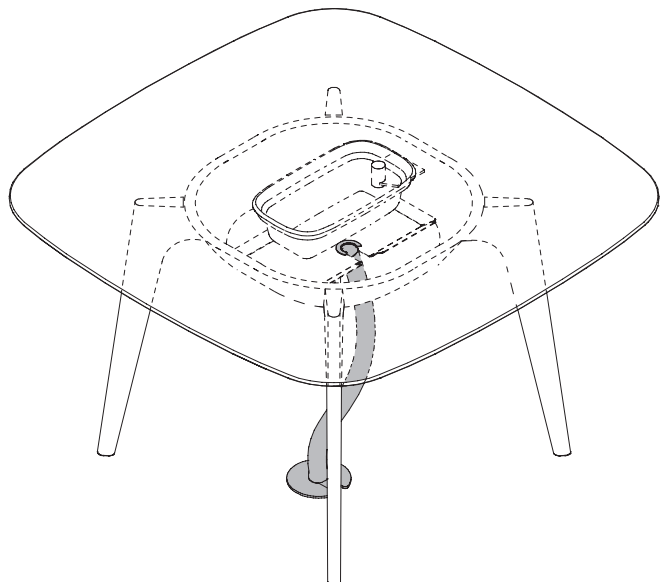

## INSPIRATIONS



TIMBA Table high with Power Bowl and mesh tube.

---



TIMBA Table with Power Bowl, TIMBA Stool and Bay Chair.

## INSPIRATIONS



TIMBA Table with Power Bowl and TIMBA Stool.



TIMBA Table high with Power Bowl and TIMBA Stool.

## COLOURS & MATERIALS - TABLETOP

### MELAMINE: Basic colours<sup>3</sup>



MW white

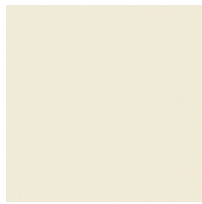

MQ office white



MC canvas



MP platinum



TM clay



MH stone grey



MA aluminium



MS slate

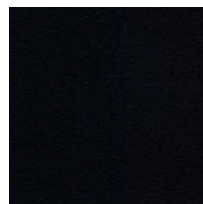

MB basalt



MD urban grey

### MELAMINE: Additional basic colours<sup>1,3</sup>

### MELAMINE: Décor colours<sup>1,3</sup>

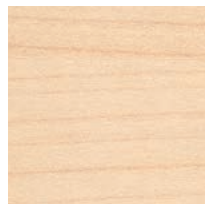

AR maple

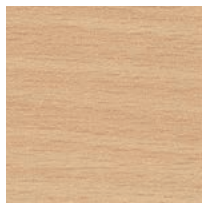

BH beech light



NG walnut grey



EZ oak vicenza

### MELAMINE: Accent colours<sup>1,3</sup>



TX mustard



TH marino blue



TS fern green

### MELAMINE: Décor colours with texture<sup>1,3</sup>

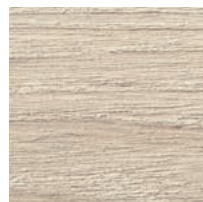

CE elm white



CO coco

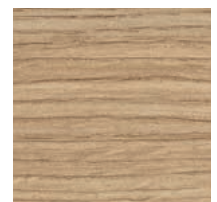

EA oak aragon

### MDF SURFACES: Powder-coated<sup>1,2</sup>

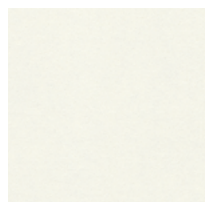

FS white

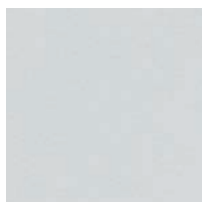

FT platinum

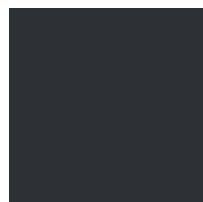

FU anthracite

### VENEER: Oak<sup>1,2</sup>

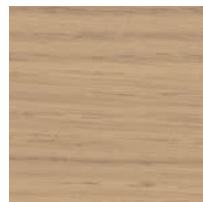

EY oak, silt

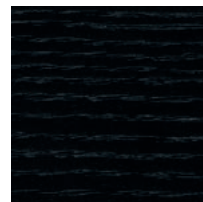

EV oak, volcano



EG oak grey

<sup>1</sup> not available for 13 mm compact desk top

<sup>2</sup> not available for 19 mm chipboard

<sup>3</sup> not available for 25 mm MDF board

## COLOURS & MATERIALS - FRAME

### SHAPED WOOD: Lacquered

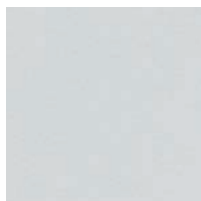

PL platinum



AT anthracite

### STEEL: Powder-coated

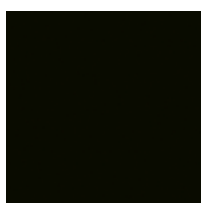

SZ black

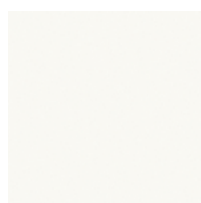

WI white

### SOLID WOOD: Oak

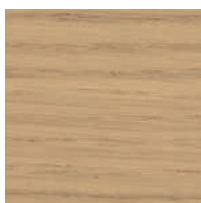

HC natural oak



HD oak graphite

## BENE WORKS SUSTAINABLY

Bene plays a leading role in responsible environmental management. It is practised throughout all company divisions—from product development, procurement, production and logistics to product recycling. Bene considers ecology to be a central element of its responsible and sustainable corporate strategy. Bene sees the legal regulations as minimum requirements and strives for better and more sustainable environmental protection throughout the group. The Bene principle in environmental policy is: **Avoidance—Minimisation—Recycling—Disposal.**

### TIMBA TABLE—ECOLOGICAL STANDARDS

- 95.6% recyclable
- 83.8% of contents are renewable raw materials
- 34.64% of contents are recycled product materials (12.84% post-consumer, 21.81% pre-consumer)
- 22.29% of contents are recycled product materials that comply with LEED (12.84% post-consumer, 21.81% pre-consumer)
- Resource-conserving product design
- Use of certified wood (chain of custody)
- Use of materials tested for presence of hazardous substances
- No PVC, chromium, lead or mercury
- Individual parts can be sorted according to homogeneous categories
- Recyclable and with positive contribution to the carbon footprint (average 135.31 kg CO<sub>2</sub>)

## TIMBA TABLE LEED POINTS

The Leadership in Energy and Environmental Design (LEED) is a system to classify ecological construction. It was developed by the U.S. Green Building Council. As an internationally recognised standard, it defines numerous standards for environmentally friendly, resource conserving and sustainable construction. The use of the TIMBA Table is an important contribution to LEED certification. The following criteria for this are from »LEED 2009 for Commercial Interiors«:

MR Credit 4	Recycling share	up to 2 points
MR Credit 5	Regional materials	up to 2 points
MR Credit 7	Certified wood	up to 1 point
IEQ Credit 4.5	Material with low hazardous substance content	up to 1 point

### TIMBA TABLE MATERIAL COMPONENTS\*

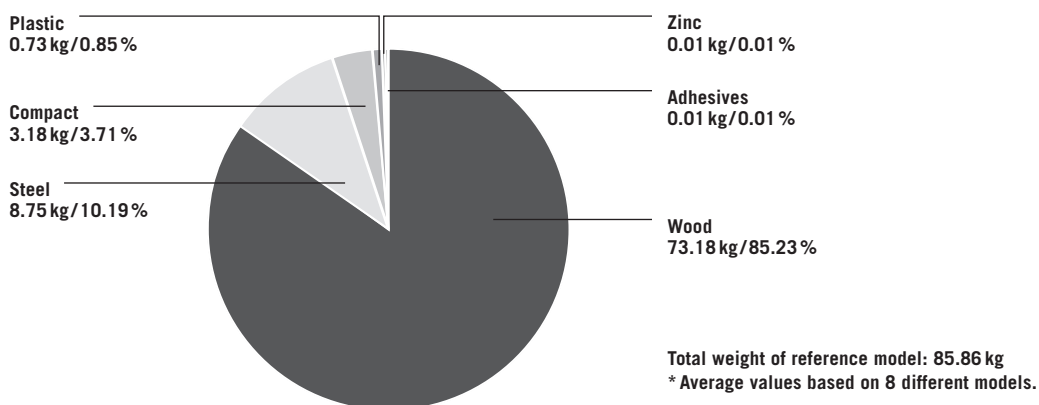

Environment-related information about Bene: [www.bene.com/sustainability](http://www.bene.com/sustainability)

