

System 70

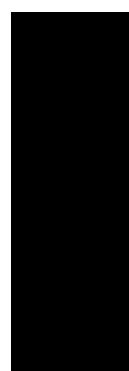

technical

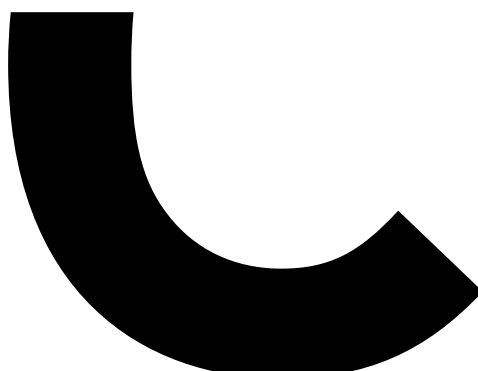

System 70 panels

System 70 is an extension of the System 30 and System 45 family of dividing panel systems. Integrated cable reticulation, rigidity and stackability are achieved with an economy of parts and materials. Elegant simplicity, strength and quality engineering.

Index

panels **02-05**

junctions connectors **06-08**

junction post **9**

panel combinations **10-11**

worksurfaces **12**

cable reticulation **13**

accessories **14-15**

core storage range **16**

product specifications **17**



Panels

base panels

Key Features

- High flexibility with fast assembly, reconfiguration and relocation requiring a single allen key.
- Panels are 70 mm thick with (load bearing) top transom rail and off-module panel capability.
- Minimal componentry required for panel junctions available in 90°, 120° and linear.
- Base panels can accept stackable (add-on) panels to increase screen height.
- Extensive selection of panel types, colours and finishes.
- All components are reusable.
- Flush mounted double sided cable ducts. Suitable for Australian and international wiring systems.
- Choice of standard panel construction, optional pinable or acoustic sound absorbing panel cores.
- Seamless compatibility with comprehensive ranges of desking, storage, tables and accessory options.
- Removable feature divider available in acrylic or laminated glass in either 6 mm or 10 mm thick. Must be specified separately to the panel.

BASE PANELS

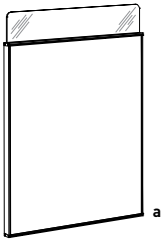

code S70.S1-TT

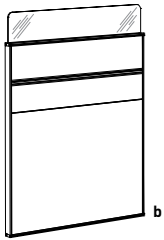

code S70.SP1-TT

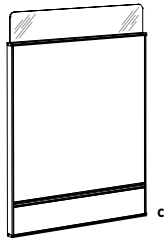

code S70.SBP1-TT

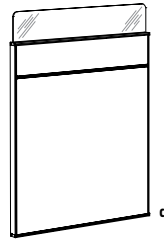

code S70.S2-TT

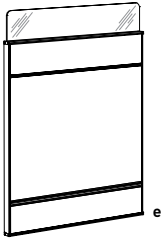

code S70.SBP2-TT

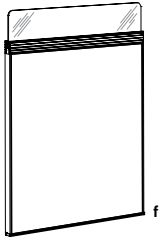

code S70.S1-FWT

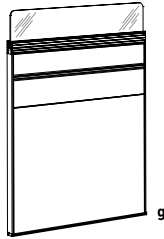

code S70.SP1-FWT

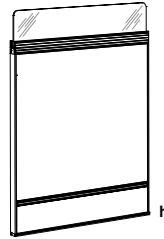

code S70.SBP1-FWT

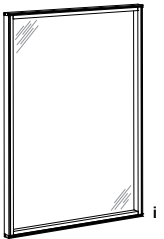

code S70.G1-1

code S70.G1-2

code S70.G1-3

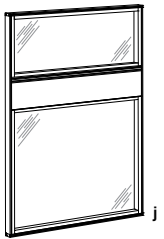

code S70.GP1-1

code S70.GP1-2

code S70.GP1-3

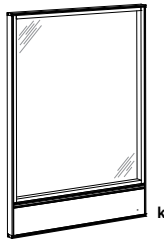

code S70.GBP1-1

code S70.GBP1-2

code S70.GBP1-3

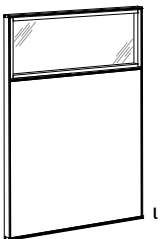

code S70.SG1-1

code S70.SG1-2

code S70.SG1-3

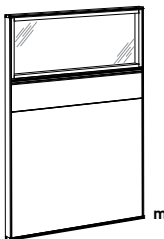

code S70.SGP1-1

code S70.SGP1-2

code S70.SGP1-3

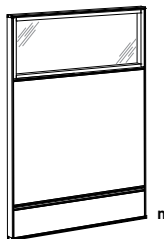

code S70.SGBP1-1

code S70.SGBP1-2

code S70.SGBP1-3

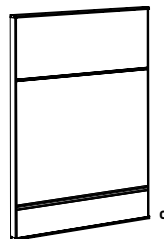

code S70.SGBP

- a _ Solid panel with removable feature divider top rail.
- b _ Two piece solid panel with mid duct and removable feature divider top rail.
- c _ Solid panel with base duct and removable feature divider top rail.
- d _ Two piece solid panel with mid transom and removable feature divider rail.
- e _ Two piece solid panel with base duct, mid transom and removable feature divider.
- f _ Solid panel with function wall top transom.
- g _ Two piece solid panel with function wall top transom and mid duct.
- h _ Solid panel with function wall top transom and base duct.
- i _ Centre full glazed panel.
Offset full flush glazed panel.
Double full flush glazed panel.
- j _ Centre full glazed panel with mid duct.
Offset full flush glazed panel with mid duct.
Double full flush glazed panel with mid duct.
- k _ Centre full glazed panel with base duct.
Offset full flush glazed panel with base duct.
Double full flush glazed panel with base duct.
- l _ Centre partial glazed panel.
Offset partial flush glazed panel.
Double partial flush glazed panel.
- m _ Centre partial glazed panel with mid duct.
Offset partial flush glazed panel with mid duct.
Double partial flush glazed panel with mid duct.
- n _ Centre partial glazed panel with base duct.
Offset partial flush glazed panel with base duct.
Double partial flush glazed panel with base duct.
- o _ Two piece solid panel with mid transom and base duct.

STANDARD SIZES - BASE PANELS

panel height (mm)	panel widths (mm)									
	450	600	750	800	900	1200	1500	1800	2100	2400
900	•	•	•	•	•	•	•	•	•	•
1050	•	•	•	•	•	•	•	•	•	•
1200	•	•	•	•	•	•	•	•	•	•
1350	•	•	•	•	•	•	•	•	•	•
1500	•	•	•	•	•	•	•	•	•	•
1800	•	•	•	•	•	•	•	•	•	•
2100	•	•	•	•	•	•	•	•	•	•
2400	•	•	•	•	•	•	•	•	•	•

nb. Special sizes available on request.

Panels

base panels | void panels

Void panels

- Void panels have a raised bottom rail creating a 300mm/400mm void between the underside of the panel and the floor.

BASE PANELS

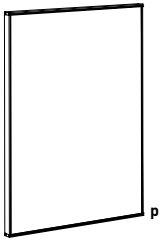

code S70.S1

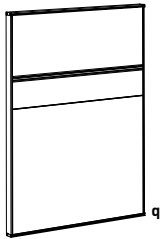

code S70.SP1

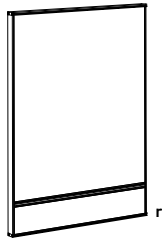

code S70.SBP1

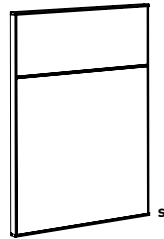

code S70.S2

- p _ Solid panel.
- q _ Two piece solid panel with mid duct.
- r _ Solid panel with base duct.
- s _ Two piece solid panel with mid transom.

VOID PANELS

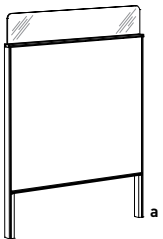

code S70.V1-TT



code S70.VP1-TT

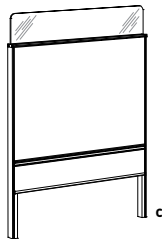

code S70.VBP1-TT

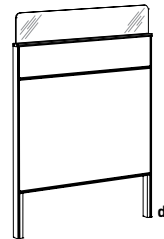

code S70.V2-TT

- a _ Solid panel with removable feature divider top rail.
- b _ Two piece solid panel with mid duct and removable feature divider top rail.
- c _ Solid panel with base duct and removable feature divider top rail.
- d _ Two piece solid panel with mid transom and removable feature divider rail.
- e _ Two piece solid panel with mid transom, base duct and removable feature divider rail.
- f _ Solid panel with function wall top transom.
- g _ Two piece solid panel with mid duct and function wall top transom.
- h _ Solid panel with base duct and function wall top transom.
- i _ Solid panel.
- j _ Two piece solid panel with mid duct.
- k _ Solid panel with base duct.
- l _ Two piece solid panel with mid transom.



code S70.VBP2-TT

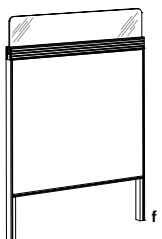

code S70.V1-FWT

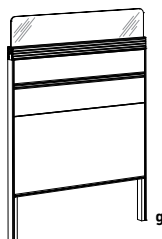

code S70.VP1-FWT

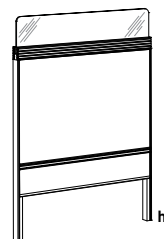

code S70.VBP1-FWT

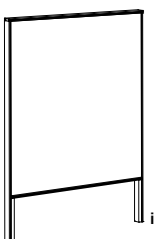

code S70.V1

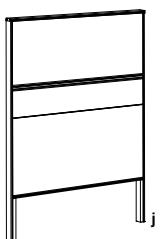

code S70.VP1

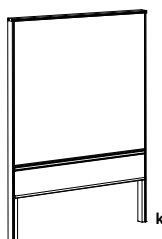

code S70.VBP1

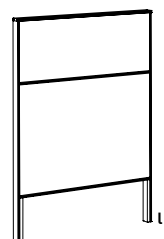

code S70.V2

STANDARD SIZES - VOID PANELS

		panel widths (mm)									
		450	600	750	800	900	1200	1500	1800	2100	2400
panel heights (mm)	900	•	•	•	•	•	•	•	•	•	•
	1050	•	•	•	•	•	•	•	•	•	•
	1200	•	•	•	•	•	•	•	•	•	•
	1350	•	•	•	•	•	•	•	•	•	•
	1500	•	•	•	•	•	•	•	•	•	•
	1800	•	•	•	•	•	•	•	•	•	•
	2100	•	•	•	•	•	•	•	•	•	•
2400	•	•	•	•	•	•	•	•	•	•	

nb. Special sizes available on request.

Panels

void panels | stacker panels

VOID PANELS

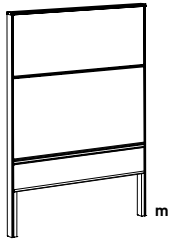

code S70.VBP2

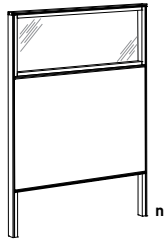

code S70.VSG1-1
code S70.VSG1-2
code S70.VSG1-3

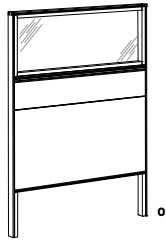

code S70.VSGP1-1
code S70.VSGP1-2
code S70.VSGP1-3

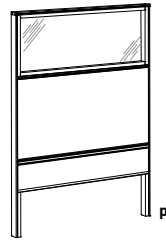

code S70.VSGBP1-1
code S70.VSGBP1-2
code S70.VSGBP1-3

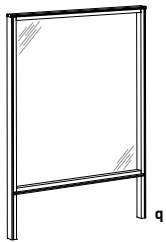

code S70.VG1-1
code S70.VG1-2
code S70.VG1-3

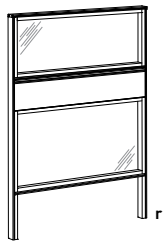

code S70.VGP1-1
code S70.VGP1-2
code S70.VGP1-3

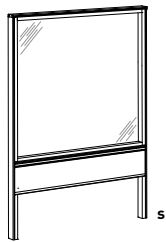

code S70.VGBP1-1
code S70.VGBP1-2
code S70.VGBP1-3

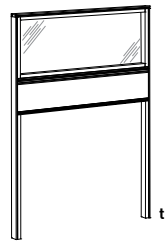

code S70.RGP1-1
code S70.RGP1-2
code S70.RGP1-3

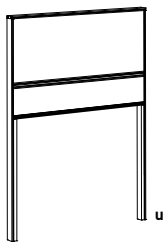

code S70.RP1-TT

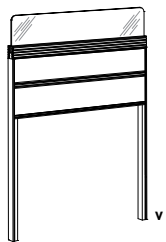

code S70.RP1-FWT

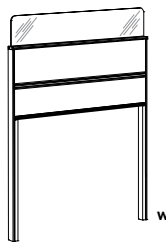

code S70.RP1

m_ Two piece solid panel with mid transom and base duct.

n _ Centre partial glazed panel.
Offset partial flush glazed panel.
Double partial flush glazed panel.

o _ Centre partial glazed panel with mid duct.
Offset partial flush glazed panel with mid duct.
Double partial flush glazed panel with mid duct.

p _ Centre partial glazed panel with base duct.
Offset partial flush glazed panel with base duct.
Double partial flush glazed panel with base duct.

q _ Centre full glazed panel.
Offset full flush glazed panel.
Double full flush glazed panel.

r _ Centre full glazed panel with mid duct.
Offset full flush glazed panel with mid duct.
Double full flush glazed panel with mid duct.

s _ Centre full glazed panel with base duct.
Offset full flush glazed panel with base duct.
Double full flush glazed panel with base duct.

t _ Centre full glazed panel with base duct.
Offset full flush glazed panel with base duct.
Double full flush glazed panel with base duct.

u _ Solid panel with base duct.

v _ Solid panel with base duct and function wall top transom.

w _ Solid panel with base duct and removable feature divider.

STACKER PANELS

Stacker panels attach to top of base or void panels increasing overall height. They may be added or removed as requirements change.

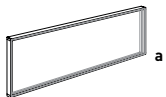

code S70.S1-ST

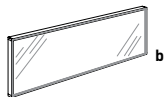

code S70.G1-1-ST
code S70.G1-2-ST
code S70.G1-3-ST

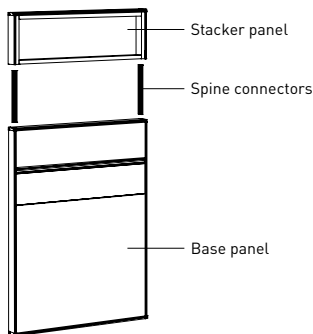

a _ Solid panel.

b _ Centre full glazed panel.
Offset full flush glazed panel.
Double full flush glazed panel.

STANDARD SIZES - STACKER PANELS

		panel widths (mm)							
		450	600	750	800	900	1200	1500	1800
heights (mm)	150	•	•	•	•	•	•	•	•
	300	•	•	•	•	•	•	•	•
	450	•	•	•	•	•	•	•	•

nb. Special sizes available on request.

Panels

service access | stabilising foot | finishes

SERVICE ACCESS OPTIONS FOR DUCTED PANELS

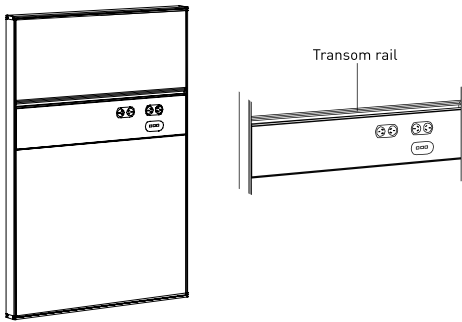

Direct access.
Services outlets visible, flush mounted to duct face.

STABILISING FOOT

Stabilising feet attach to side verticals of System 70 panels providing support for freestanding panels and unsupported panel runs.

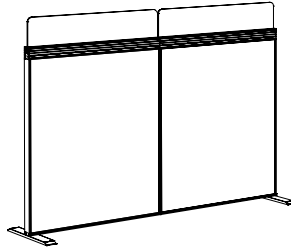

code SF-FT-1

REMOVABLE FEATURE DIVIDER INFILLS

Removable feature Divider Infills are available in a wide variety of materials including laminated glass and perspex, in either 6 mm or 10 mm thicknesses. Heights and widths can be varied to suit particular requirement and must be specified.

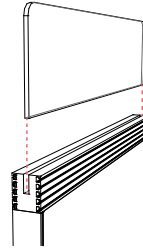

code SA-RFD

FINISHES

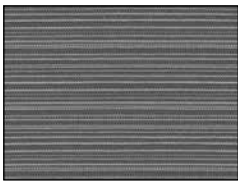

fabric

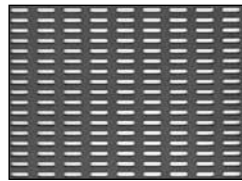

perforated metal
CR perforation

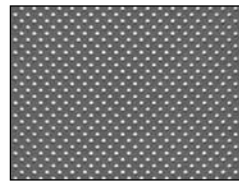

perforated metal
MW perforation

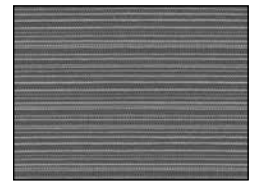

pinable fabric screen



powder coat MDF



laminate



veneer

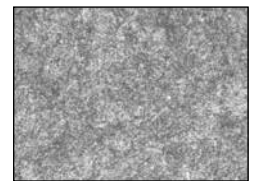

echo panel

Panel faces can be specified in a variety of finishes as illustrated.

Junction Connectors

180° straight junction | 90° two way open junction | 90° two way closed junction | 90° off module junction
 | transition height junctions

Junction connectors for transition height junctions are specified per each not per set. Each of the examples shown below indicate the connector product codes and the quantity required of each to achieve the junction.

180° STRAIGHT JUNCTION

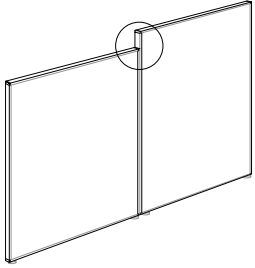

TRANSITION HEIGHT PANELS

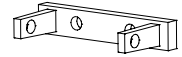
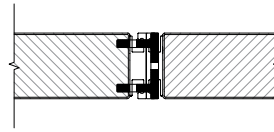
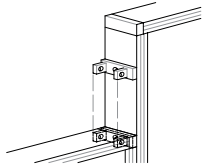

code A3380021

connectors required

1-wall starter bracket

90° TWO WAY OPEN JUNCTION

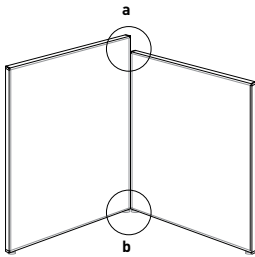

TRANSITION HEIGHT PANELS

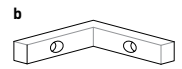
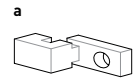
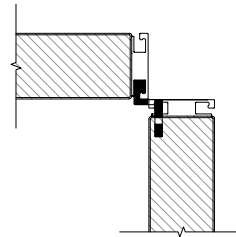
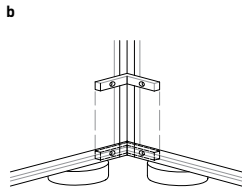
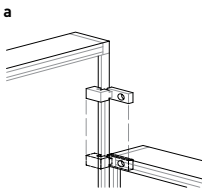

connectors required

a_1-type B-671 013 connector

b_1-type B-671 005 connector

90° TWO WAY CLOSED JUNCTION

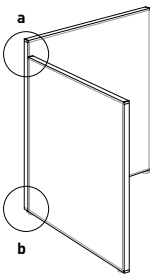

TRANSITION HEIGHT PANELS

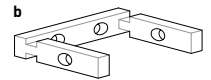
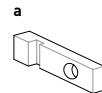
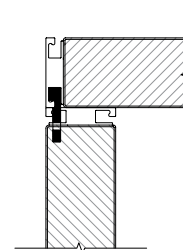
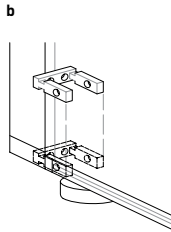
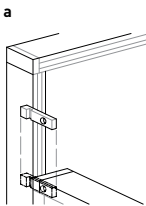

connectors required

a_1-type B-671 001 connector

b_1-type B-671 025 connector

90° OFF MODULE JUNCTION

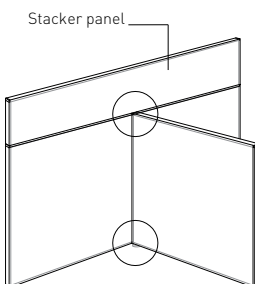

TRANSITION HEIGHT PANELS

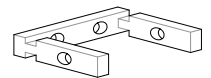
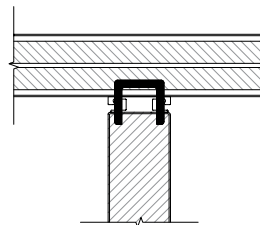
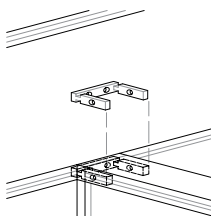

connectors required

2 -type B-671 025 connectors

Junction Connectors

straight junction | 90° two way open junction | 90° two way closed junction | 90° three way open junction
 | 90° three way closed junction | common height panels

Each common height junction has an individual product code no. as shown.
 Connectors are specified as one set for each junction.

By specifying the code no's and quantities of the **junctions required**,
 the appropriate quantity and type of connectors will be supplied.

STRAIGHT JUNCTION

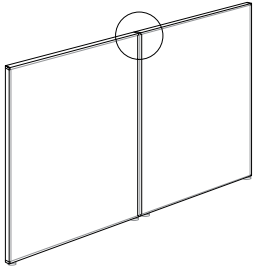

COMMON HEIGHT PANELS

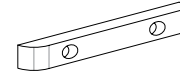
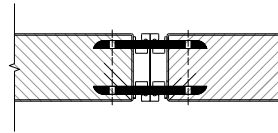
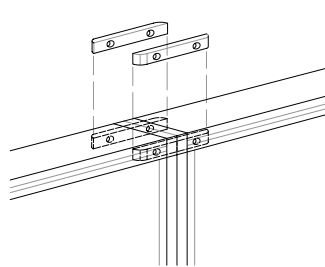

code S45.J180.1W.S (base panel set)
 Junction connector set comprises
 2-type B-671 011 connectors

code S45-SU.J180.1W.S
 [suspended & void panel set]
 Junction connector set comprises
 4-type B-671 011 connectors

90° TWO WAY OPEN JUNCTION

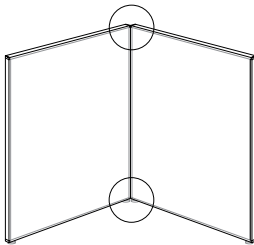

COMMON HEIGHT PANELS

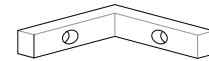
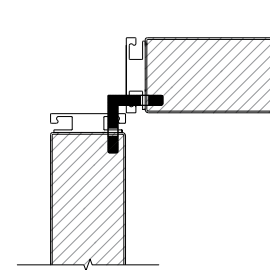
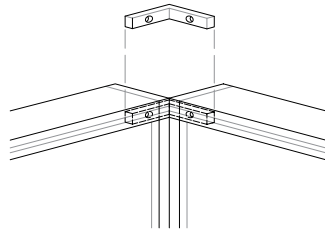

code S45.J90.2W.O
 Junction connector set comprises
 2-type B-671 005 connectors

90° TWO WAY CLOSED JUNCTION

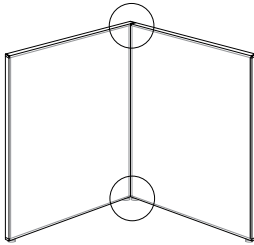

COMMON HEIGHT PANELS

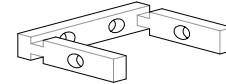
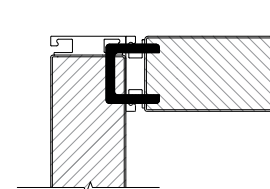
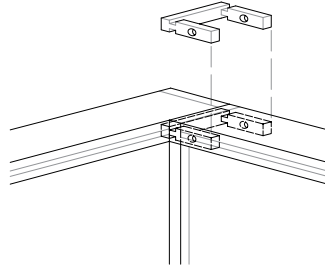

code S70.J90.2W.C
 Junction connector set comprises
 2-type B-671 025 connectors

90° THREE WAY OPEN JUNCTION

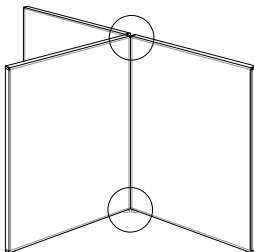

COMMON HEIGHT PANELS

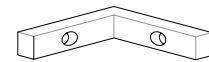
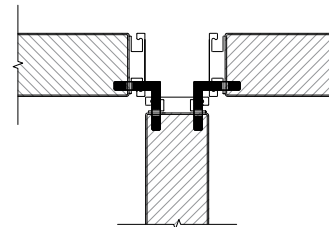
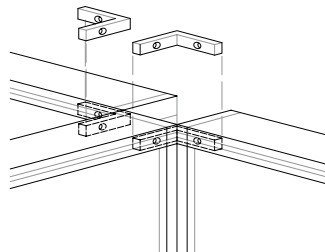

code S45.J90.3W.O
 Junction connector set comprises
 4-type B-671 005 connectors

90° THREE WAY CLOSED JUNCTION

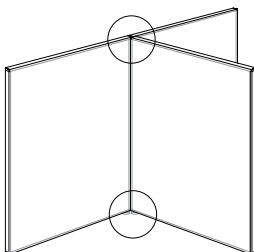

COMMON HEIGHT PANELS

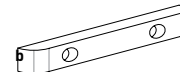
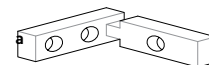
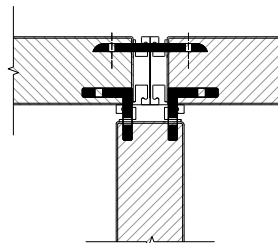
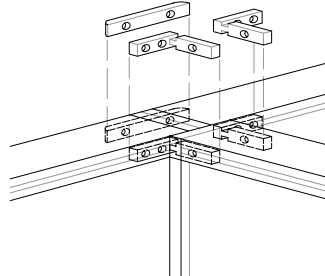

code S45.J90.3W.C
 Junction connector set comprises
 a_4-type B-671 003 connectors and
 b_2-type B-671 011 connector

Junction Connectors

90° off module junction | 90° four way junction | 90° four way umbilical junction | 120° three way closed junction | 120° three way umbilical junction | common height panels

Each common height junction has an individual product code no. as shown. Connectors are specified as one set for each junction.

By specifying the code no's and quantities of the **junctions required**, the appropriate quantity and type of connectors will be supplied.

90° OFF MODULE JUNCTION

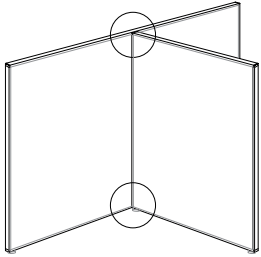

COMMON HEIGHT PANELS

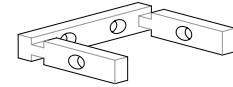
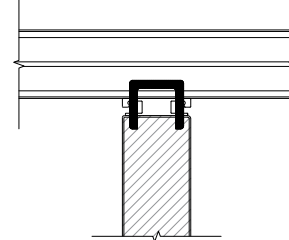
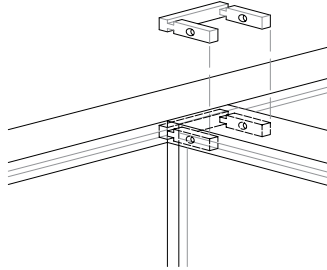

code S70.J90.3W.OM
Junction connector set comprises
2-type B-671 025 connectors

120° THREE WAY CLOSED JUNCTION

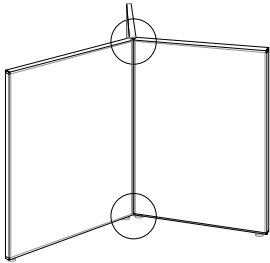

COMMON HEIGHT PANELS

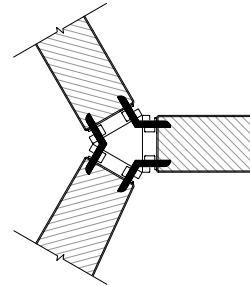
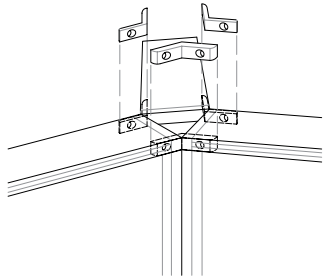

code S45.J120.3W.C
Junction connector set comprises
6-type B-671 004 connectors

90° FOUR WAY JUNCTION

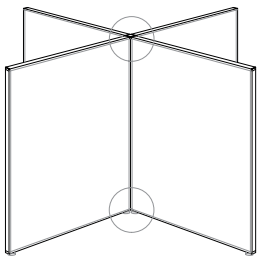

COMMON HEIGHT PANELS

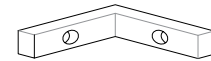
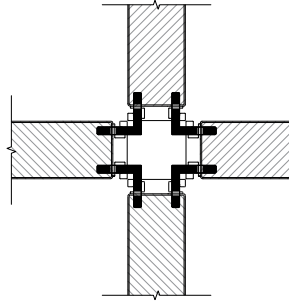
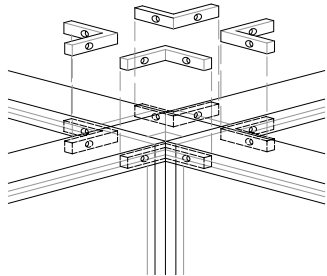

code S45.J90.4W.C
Junction connector set comprises
8-type B-671 005 connectors

Junction Post

end post support | 90° two way corner post | 180° straight corner post | 90° three way corner post
 | 90° four way corner post

Corner junction post for System 70 panels. Forms two way, three way and four way junctions with either common height or transition height panels.

Cables can be routed to mid ducted panels from floors and skirtings. Specify cabling requirements and panel heights.

END SUPPORT POST

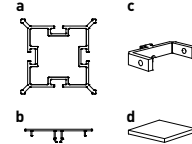
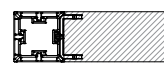
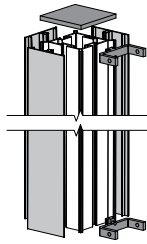
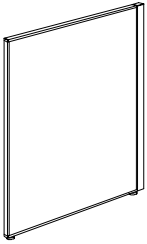

code S70.JP.1W
 a_1-type P11184 post extrusion
 b_3-type P11185 cover extrusion
 c_2-type B-671-026 connector
 d_1-type A3380027 post cap

90° TWO WAY CORNER POST

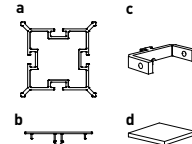
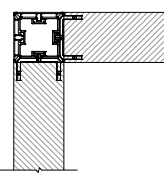
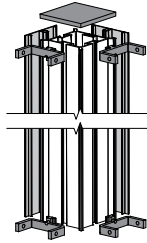
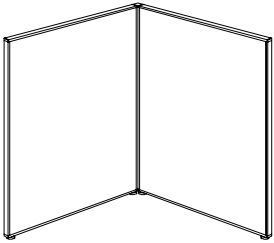

code S70.JP.2W
 a_1-type P11184 post extrusion
 b_2-type P11185 cover extrusion
 c_4-type B-671-026 connector
 d_1-type A3380027 post cap

180° STRAIGHT CORNER POST

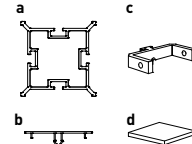
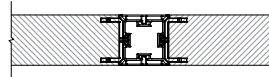
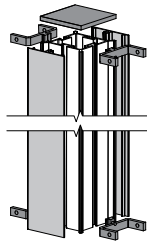
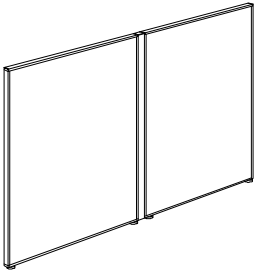

code S70.JP.2S
 a_1-type P11184 post extrusion
 b_2-type P11185 cover extrusion
 c_4-type B-671-026 connector
 d_1-type A3380027 post cap

90° THREE WAY CORNER POST

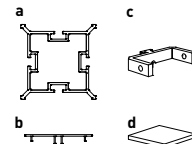
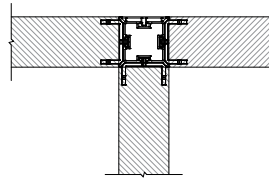
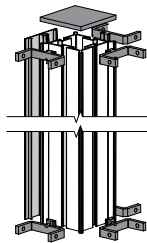
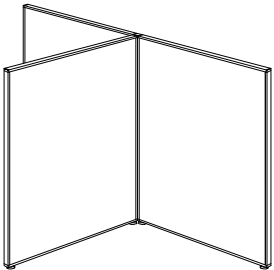

code S70.JP.3W
 a_1-type P11184 post extrusion
 b_1-type P11185 cover extrusion
 c_6-type B-671-026 connector
 d_1-type A3380027 post cap

90° FOUR WAY CORNER POST

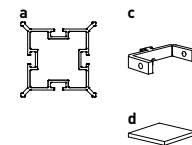
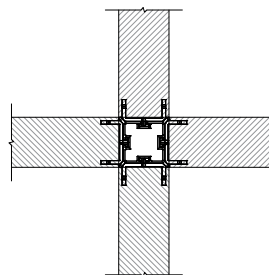
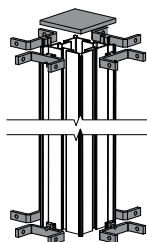
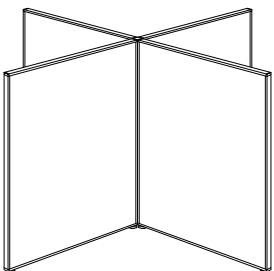

code S70.JP.4W
 a_1-type P11184 post extrusion
 c_8-type B-671-026 connector
 d_1-type A3380027 post cap

System 70 panel combinations

system 30 | centric | marina

SYSTEM 70 PANELS WITH CENTRIC LINEAR DESKING

System 70 mid-ducted, floor standing fabric panels configured as spine wall, with integrated cable reticulation and face accessed power and data outlets. Centric linear desks with mobile pedestals and transom hung shelf to each position.

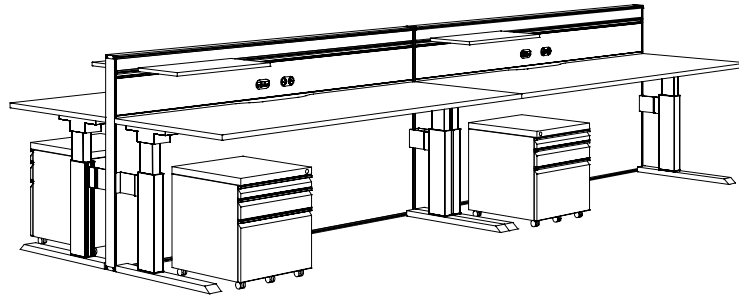
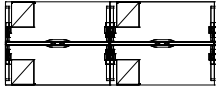

SYSTEM 70 PANELS WITH SYSTEM 30 SUSPENDED PANEL AND MARINA WORKSTATIONS

System 70 mid-ducted floor standing fabric panels configured as spine wall, with integrated cable reticulation and face accessed power and data outlets. Marina 90° height adjustable workstations with a System 30 suspended panel attached as a privacy screen. Mobile pedestals to each position.

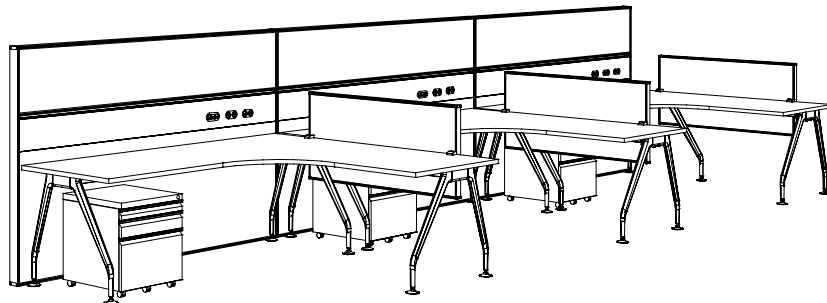
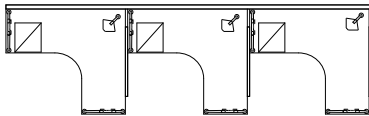

SYSTEM 70 PANELS WITH CENTRIC LINEAR DESKS AND SYSTEM 30 SUSPENDED PANELS

System 70 mid-ducted, floor standing fabric panels configured as spine wall, with integrated cable reticulation and face accessed power and data outlets. Function wall top rail with removable glass feature divider. Centric linear desks with linear connected returns. System 30 suspended panels attached with clamp brackets as privacy screens. Mobile pedestals to each position.

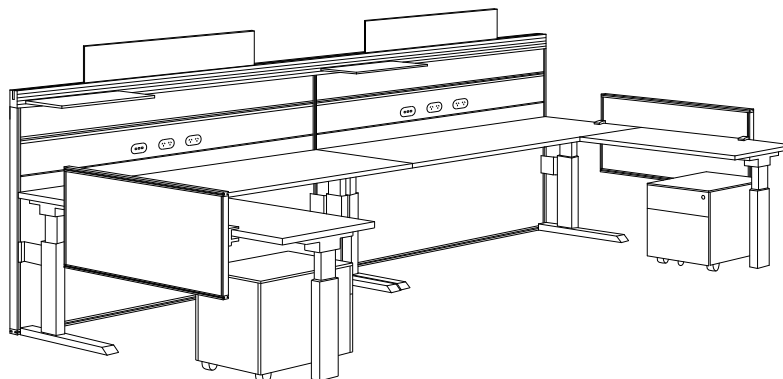
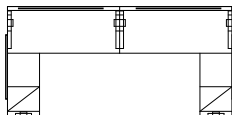

SYSTEM 70 PANELS WITH MARINA DESKING

System 70 mid-ducted, floor standing, partial glazed/fabric panels, with integrated cable reticulation and face accessed power and data outlets. Return wall features, solid fabric panels with mid ducting and clip on book shelves. Marina desking in U-shape configuration with front modesty panel and 2 mobile pedestals.

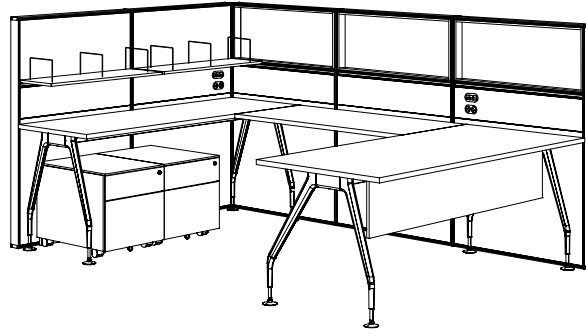
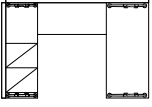

SYSTEM 70 PANELS WITH 120 DEGREE CENTRIC WORKSTATIONS

System 70 mid-ducted, floor standing panels with glazed stacker panels above. Integrated mid-height cable reticulation and face accessed power and data outlets. Centric 120 degree workstations with a mobile pedestal to each position.

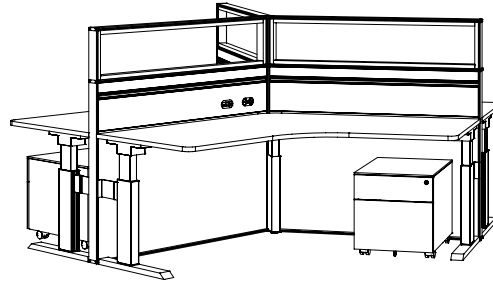
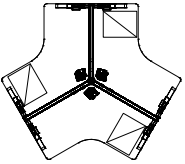

SYSTEM 70 PANELS WITH REMOVABLE FEATURE DIVIDER AND CENTRIC WORKSTATIONS

System 70 base ducted floor standing fabric panels with removable feature divider and integrated cable reticulation with face accessed power and data outlets. Centric 90 degree workstations with a mobile pedestal to each position.

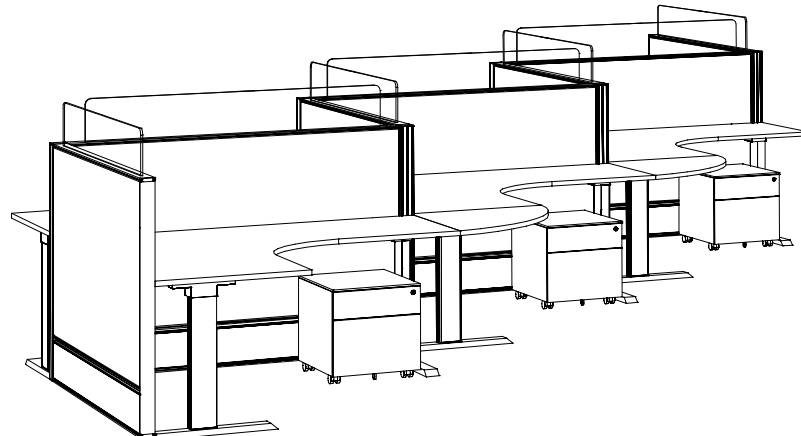
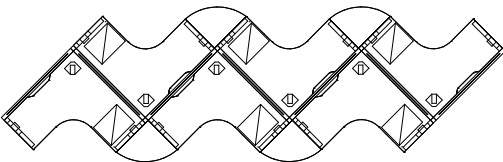

Worksurfaces

typical workstation clusters for system 70 | worksurface support brackets | worksurface support legs

Worksurfaces

Worksurfaces can be specified either 25 mm or 33 mm thick. Available finishes include selected laminates, timber veneers and powder coated MDF in a range of colours.

There is a wide selection of shapes and sizes to ensure the right solution for task specific requirements. Edge finishes and shapes also offer many choices with custom shapes available on request.

TYPICAL WORKSTATION CLUSTERS FOR SYSTEM 70

Cluster examples using various shaped work surfaces.

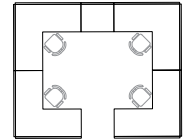
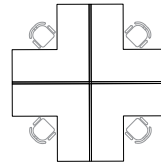
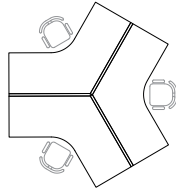
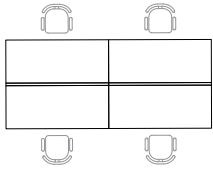

WORKSURFACE SUPPORT BRACKETS

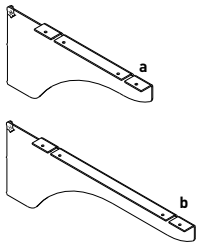

a_code S45.D400LH-C
b_code S45.D600LH-C
length a_358 mm/b_495 mm
 Curved desk support brackets.
 Left hand.

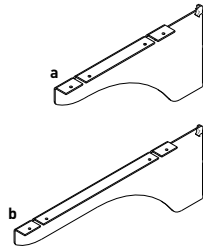

a_code S45.D400RH-C
b_code S45.D600RH-C
length a_358 mm/b_495 mm
 Curved desk support brackets.
 Right hand.

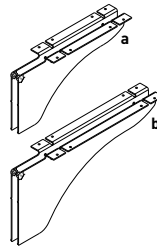

a_code S45.D400D-C
b_code S45.D600D-C
length a_358 mm/b_495 mm
 Curved double desk support brackets.

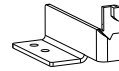

code S45.FTS-LH
 Front top support brackets.
 Left hand.

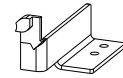

code S45.FTS-RH
 Front top support brackets.
 Right hand.

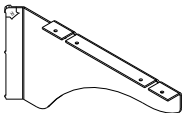

code S45.D400LH-45-C
length 350 mm
 Curved desk support brackets.
 Left hand.

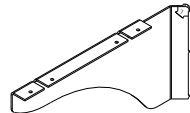

code S45.D400RH-45-C
length 350 mm
 Curved desk support brackets.
 Right hand.

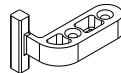

code S45/PNL-LCK-GUIDE
 Panel locking guide. (Unhanded)
 (Holds panels against adjustable height work surface).



code DJ-50
length 50 mm x 50 mm
 Underdesk joining plates.

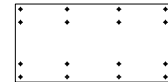

code DJ-300/400/500/600 mm
depth 150 mm
width 300/400/500/600 mm
 Underdesk joining plate.

WORKSURFACE SUPPORT LEGS

Fixed height

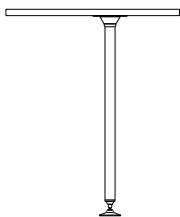

code QLIF-NB-STRT
dia. 28 mm dia. QED
height Leg 695 mm plus worksurface.

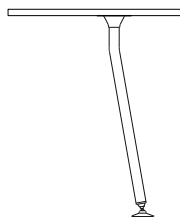

code QLIF-NB-10°
dia. 28 mm dia. QED
height Leg 695 mm plus work surface.

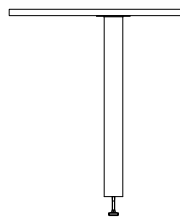

code U10 leg
dia. 70 mm dia. leg
height Leg 687 mm plus work surface.

WORKSURFACE SUPPORT LEGS

Height adjustable

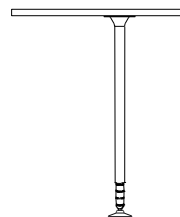

code QED3-STRT
height Height adjustable leg 610 mm to 735 mm plus work surface.

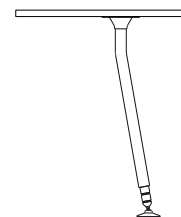

code QED3-10°
height Height adjustable leg 610 mm to 735 mm plus work surface.

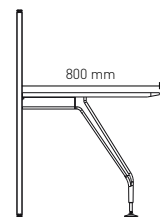
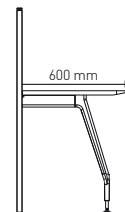

code Marina leg
height Height adjustable leg 625 mm to 705 mm plus work surface.

Cable Reticulation

interpower soft wiring system | cable routing | power blades | umbilical | power poles

Cable routing

System 70 offers a number of cable routing options. They can be combined to satisfy specific requirements while always providing easy access and efficient cable management throughout entire layouts.

Cables can be routed to panels from ceiling, walls or floors by utilising umbilicals, power blades or power poles.

POWER BLADES

Access from ceiling or floor. Lengths to order. Range of colours.

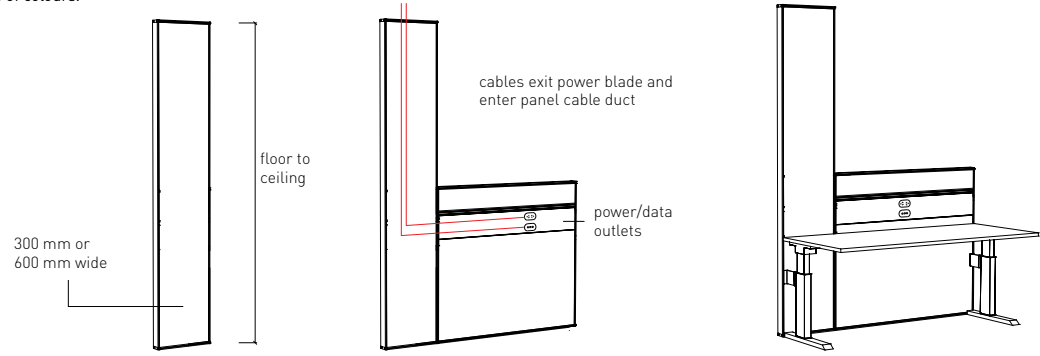

POWER POLES

Full height corner posts, or power poles, are able to route cables from ceilings, floors and skirtings into panel ducts. Please specify cabling requirements, adjoining panels and ceiling heights.

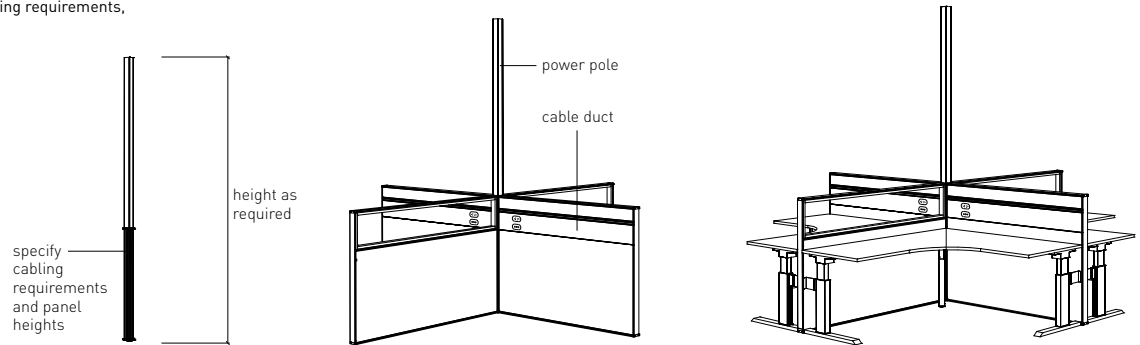

UMBILICALS

Access from ceiling or floor. Lengths to order. Range of colours.

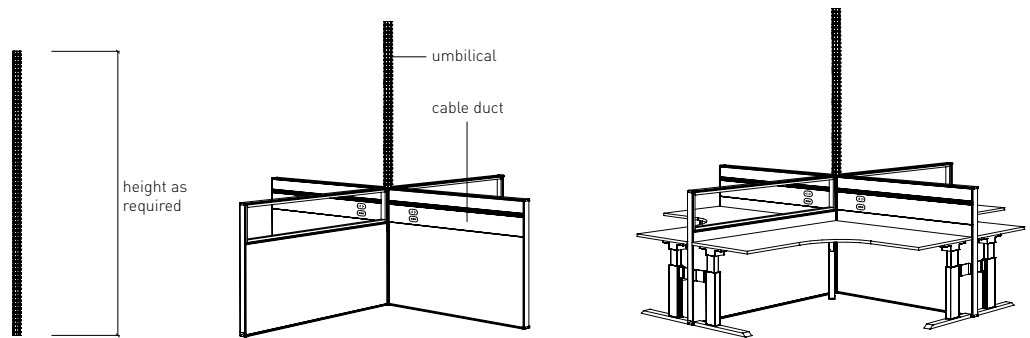

STANDARD DUCT OUTLET POSITIONS

Standard duct face punch out positions for power/data outlet modules. Suits all widths.



There are numerous outlet combinations available for each option. Refer to Schiavello Interpower brochure SCH/W05-C for complete product information and technical specifications.



Accessories

interpower | humanscale ergonomic accessories

INTERPOWER SOFTWIRING SYSTEM

Schiavello Interpower softwiring system delivers power and lighting to workstations. The system is easily connected, disconnected or relocated without the need to isolate the power and with minimal inconvenience. All connections within Interpower systems are protected by a positive lock mechanism to prevent accidental power disconnection.



code EX-S00 (add length
i.e.600 mm lead =
EX-S00600)

Extension leads



code SS
Starter sockets

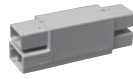

code JB-S
Junction box



code PM2H
code PM2H1VL
code PM4VL
Power modules



code NGDM/2
code NGDM/4
code NGDM/6
Data modules

HUMANSCALE ERGONOMIC ACCESSORIES

Uncompromising performance-centric design in its purest form is at the heart of every Humanscale solution. Each of the ergonomic products is designed for uncomplicated use, maximum comfort, a long serviceable life, and a minimal environmental footprint.

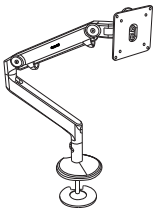

code M2CW
Monitor arm single arm

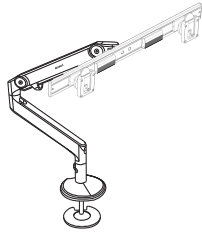

code M8DW-C
Monitor arm double

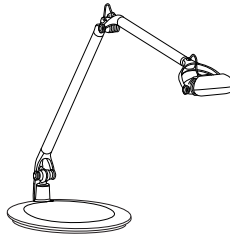

code ELUBW
Task light

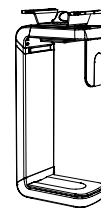

code CPU-600W
CPU600 89mm to 203mm wide
and 305mm to 508mm high
(Optional rubber spacer available)

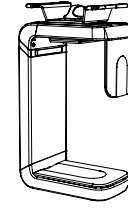

code CPU-600lite
CPU600lite 60mm to 230mm wide
and 205mm to 305mm high
(Smaller width achieved using
rubber spacer provided)

Accessories

function walls | accessories

Function walls

Mount to transom rails of panels via integral mounting detail.
Additional brackets not required.

FUNCTION WALLS

Specify width

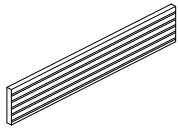

code FWT-150
height 150 mm

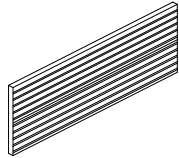

code FWT-300
height 300 mm

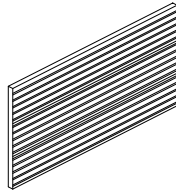

code FWT-450
height 450 mm

BENTO PLASTIC ACCESSORIES

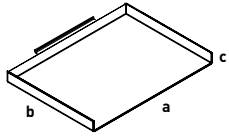

code BT/STRAY
side_a 316 mm
side_b 230.4 mm
side_c 25 mm

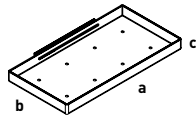

code BT/BM
side_a 316 mm
side_b 163.4 mm
side_c 25 mm

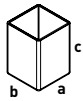

code BT/BM5
side_a 73.5 mm
side_b 73.5 mm
side_c 100 mm

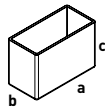

code BT/BM6
side_a 150 mm
side_b 73.5 mm
side_c 100 mm

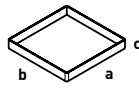

code BT/BM2
side_a 150 mm
side_b 150 mm
side_c 21.5 mm



code BT/BM3
side_a 150 mm
side_b 73.5 mm
side_c 21.5 mm



code BT/BM4
side_a 73.5 mm
side_b 73.5 mm
side_c 21.5 mm

POWDER COATED METAL ACCESSORIES

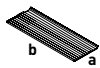

code ULT CD SHELF
side_a 200 mm
side_b 150/260/390/520 mm
CD holder

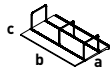

code ULT/SHLF-LINE-0600-DIV
side_a 300 mm
side_b 600/750/900/1050/1200 mm
Slimline shelf

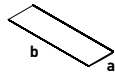

code ULT/SL/SHELF-600
side_a 225 mm
side_b 600/750/900/1050/1200 mm
Slimline mini shelf

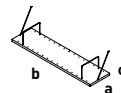

code ULT-SHLF-25
side_a 300 mm
side_b 600/750/900/1050/1200 mm
side_c 250/300/350/410 mm
Shelf

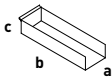

code ULT-PTRAY/SM
side_a 50 mm
side_b 158 mm
side_c 26 mm
Pencil tray - small

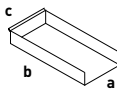

code ULT-PTRAY/LG
side_a 122 mm
side_b 319 mm
side_c 26 mm
Pencil tray - large

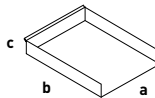

code ULT-STRAY
side_a 245 mm
side_b 319 mm
side_c 26 mm
Stationary tray (A4 portrait)

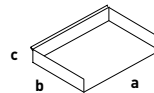

code ULT-STRAY-A4
side_a 313 mm
side_b 251 mm
side_c 26 mm
Stationary tray (A4 landscape)

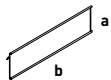

code TH/NAMEPLATE 170
side_a 49 mm
side_b 170 mm
Name plate



code TH/CH
side_a 40 mm
side_b 40 mm (overall height)
Coat hook

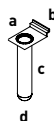

code ULT/VASE
side_a 67 mm
side_b 40 mm
side_c 125 mm
side_d 25 mm
Vase

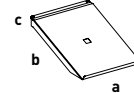

code ULT-PHTRAY
side_a 245 mm
side_b 325 mm
side_c 39 mm
Phone tray

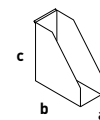

code ULT-PHBOOK
side_a 115 mm
side_b 265 mm
side_c 272 mm
Phone book holder

Core Storage Range

Mobile Pedestals - Metal

500 mm deep and 450 mm deep models
0.95 mm zinc- seal steel, anti rust carcass and drawers.
powder coated finish available in selected colours.

Operate on runners with key locking system. Injection moulded pencil drawer where shown. Timber drawer fronts optional.

CORE LOW PEDESTALS

Low pedestal - Suitable for height adjustable desks

Dimensions: 525 mm high x 450 mm wide x 500 mm deep
525 mm high x 450 mm wide x 450 mm deep

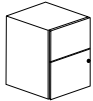

code C/MPL-2-500
height 525 mm depth 500mm
C/MPL-2-450
height 525 mm depth 450 mm

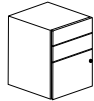

code C/MPL-3-500
height 525 mm depth 500 mm
C/MPL-3-450
height 525 mm depth 450 mm

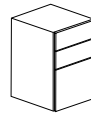

code C/MPL-3-500
height 600 mm depth 500 mm
C/MPT-3-450
height 600 mm depth 450 mm

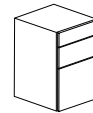

code C/MPT-2D/PD-500
height 600 mm depth 500 mm
C/MPT-2D/PD-450
height 600 mm depth 450 mm

CORE COMBO PEDESTALS

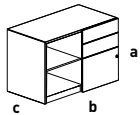

code C/CMPT-3-500-600H-SP
side_a 600 mm
side_b 900 | 1200 mm
side_c 500 mm

Core combo pedestal and open shelf.
Available as left-hand or right-hand unit.

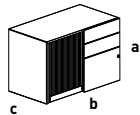

code C/CVT2-3-500-600H-SP
side_a 600 mm
side_b 900 | 1200 mm
side_c 500 mm

Core combo pedestal and tambour door. Available as left-hand or right-hand unit.

CORE VERTICAL TAMBOUR DOOR UNIT

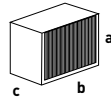

code C/CVT-2
side_a 660 mm
side_b 900 mm
side_c 512 mm

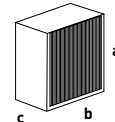

code C/CVT-3
side_a 948 mm
side_b 900 mm
side_c 512 mm

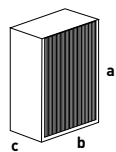

code C/CVT-4
side_a 1236 mm
side_b 900 mm
side_c 512 mm

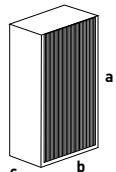

code C/CVT-5
side_a 1524 mm
side_b 900 mm
side_c 512 mm

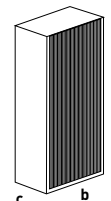

code C/CVT-6
side_a 1812 mm
side_b 900 mm
side_c 512 mm

CORE LATERAL FILE UNIT

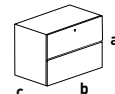

code C/LF-2
side_a 660 mm
side_b 900 mm
side_c 512 mm

2 draw file

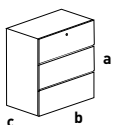

code C/LF-3
side_a 948 mm
side_b 900 mm
side_c 512 mm

3 draw file

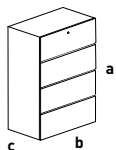

code C/LF-4
side_a 1236 mm
side_b 900 mm
side_c 512 mm

4 draw file

Product Specifications

general | panels | connectors | cable reticulation | aluminium finish | warranty



Melbourne Head Office

Schiavello (Vic) Pty Ltd
1 Sharps Road
Tullamarine VIC Australia 3043
T: 61) 3 9330 8888
F: 61) 3 9330 8899

Melbourne Showroom

Schiavello (Vic) Pty Ltd
Metropol
8 Whiteman Street
Southbank VIC Australia 3006
T: 61) 3 9674 1500
F: 61) 3 9674 1650

Adelaide

Schiavello (SA) Pty Ltd
Ground Floor, 101 Currie Street
Adelaide SA Australia 5000
T: 08) 8112 2300
F: 08) 8231 1419

Brisbane

Schiavello (Qld) Pty Ltd
265 Coronation Drive
Milton QLD Australia 4064
T: 07) 3368 3388
F: 07) 3368 2125

Canberra

Schiavello (ACT) Pty Ltd
2-6 Collie Street
Fyshwick ACT Australia 2609
T: 02) 6124 0500
F: 02) 6280 4370

Perth

Schiavello (WA) Pty Ltd
1315 Hay Street
West Perth WA Australia 6005
T: 08) 9420 6588
F: 08) 9322 1337

Sydney

Schiavello (NSW) Pty Ltd
69 Campbell Street
Surry Hills NSW Australia 2010
T: 02) 9211 3311
F: 02) 9212 3788

Singapore

Schiavello Singapore Pte Ltd
No.1 Magazine Road
#01-05 Central Mall
Singapore 059567
T: 65) 6533 8011
F: 65) 6533 2811

schiavello.com/system70

SCH/SY7003-A

Schiavello Group Pty Ltd
reserves the right to change
any or all details without
prior notice. All dimensions
stated within this document
are nominal and/or approximate
only and subject to variation.

schiavello