

# HYGIENE SHIELD COLLECTION



**schiaavello**

# A strong and versatile design

Schiavello's hygiene certified protective shields can be customised to suit your unique needs. Each shield is designed as a robust, secure structure suitable for long-term use, with the ability to be retrofitted and easily relocated to various workpoints with ease, for ongoing flexibility.



# Hygienic design certified for a safe environment

All shields have been certified by an independent Occupational Hygienist to guarantee the highest level of safety, manufactured using non-porous materials with antibacterial properties, ensuring particles from sneezing and coughing are blocked.



## High Density Workspace Divider

A durable, freestanding shield that is perfect for any high density workspace. With a large glass insert, this divider maintains visual connections between colleagues whilst simultaneously

discouraging co-workers from entering each other's space. This product is available in a range of protective materials, such as glass, laminate and antibacterial vinyl.



### Desktop Protection Shield

Suitable for any worktop size or thickness, the Desktop Protection Shield attaches to the worktop to provide a physical barrier between colleagues. A unique slide-on

bracket provides superior stability when fixed to the desk, while also offering complete flexibility to easily relocate the shield to other work surfaces.

### Extension Panel

This retro-fit solution increases the height of any panel or wall system to provide protection. The Extension Panel can be customised to any height or width that best suits your space and your needs.



# Retro-fit shield solutions to suit your workspace

All shields can be custom designed to size as a retro-fit solution to suit your space. The ability to relocate them to various worktops or tables with the use of their slide on bracket or bolt-on mechanism creates ongoing flexibility.



## Counter Protection Shield

—

The Counter Protection Shield is specially designed for retail and public spaces as a protective barrier between employees and their

customers. With brackets designed for superior strength and an access cut-out at the base, this shield is the ideal solution for all client transactions.



# ColourLab

Curated by Giulio Ridolfo and developed by Schiavello, Colourlab brings a considered and cohesive palette of finishes suited to the needs of working and living environments. The palette beautifully balances colour, texture and layering across a variety of materials.

To review a complete list of Hygiene Shield finishes please [click here](#).

## ColourLab materials and finishes

1. Laminate
2. Spotless Laminate
3. Timber Natural
4. Timber Paint
5. Timber Wash
6. Linoleum
7. Fabric
8. Metal Powder Coat

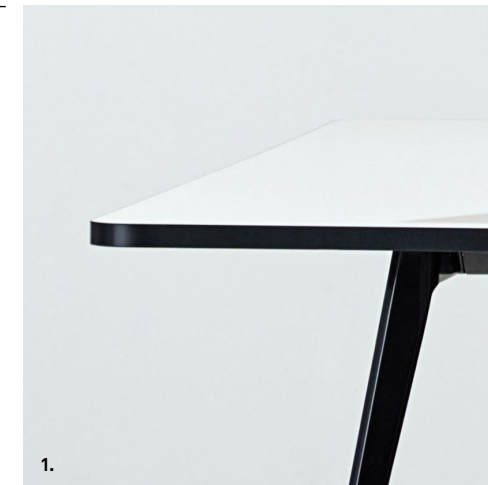

# Specifications

Counter Protection Shield

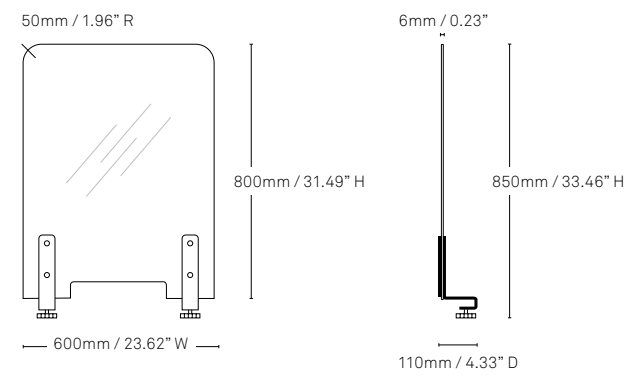

Desktop Protection Shield

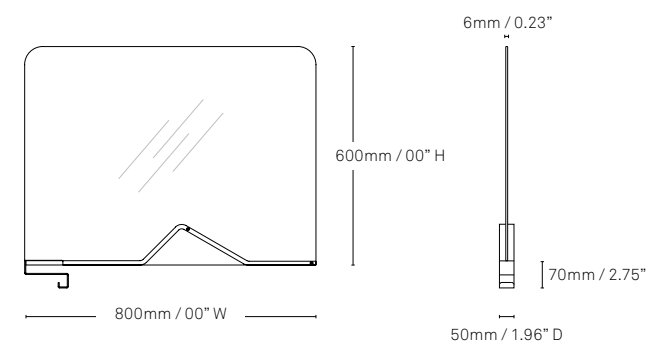

Extension Panel

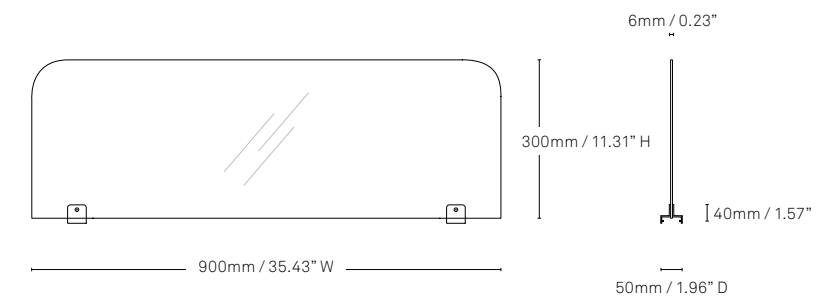

High Density Workspace Divider

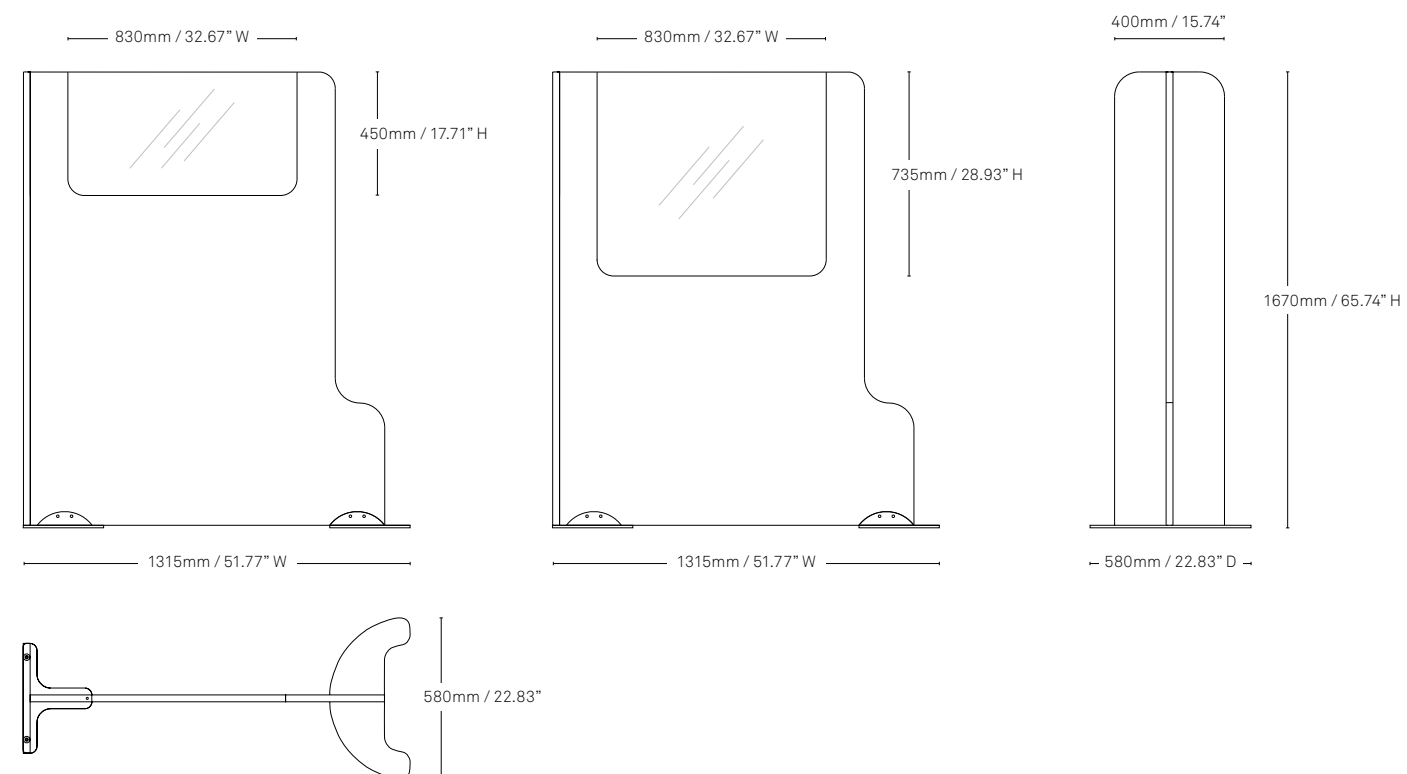



## Ecology and sustainability

Schiavello's most important commitment to sustainability is the company-wide Environmental Management System under ISO 14001. The environmental design principles realised means we design for the environment, focusing on efficient energy use and minimum emissions, longevity and durability, re-use and recycling of our products.

Our principles of ME WE (Materials, Energy, Waste Emissions) give us a simple way to think about how our operations impact the environment.

Printed on an Australian made paper stock that is PEFC Certified and made from elemental chlorine-free bleached pulp sourced from sustainably managed forests and non-controversial sources. It is manufactured by an ISO 14001 certified mill using renewable energy sources.



FS 604920

EMS 604919

## About Schiavello

Schiavello is a multi-disciplinary company dedicated to developing intelligent, inspiring, ecological and resilient solutions for the office, the home and public spaces.

Schiavello's concepts and products are developed in Australia by applying a design process that brings together the company's core design principles and engineering with the creativity of local and international designers.

The Schiavello head office and world-class manufacturing facilities are integral to our continually developing rich tapestry of knowledge. This knowledge ultimately assists us in informing the right solutions and tools for each organisation's needs and people, allowing us to consistently achieve our philosophy that 'Anything is possible'.

To find a Schiavello showroom or partner in your area, please visit [schiavellofurniture.com/find-us](https://www.schiavellofurniture.com/find-us)

All intellectual property rights and copyrights are reserved. Nothing contained in this brochure may be reproduced without written permission. Schiavello Group Pty Ltd reserves the right to change any or all details without prior notice. All dimensions stated within this document are nominal and/or approximate only and subject to variation.

SCH/C53.0D-D