

HEALTHCARE



schiaavello

Day Bed

An innovative design in Healthcare, the Day Bed encapsulates the user in comfort and creates a sense of well-being. Finished in anti-bacterial foam, the sleeper doubles as a comfortable lounge chair and a fully functional bed for when visitors spend the night. Two built in drawers provide convenience for personal belongings and are easily removed for cleaning maintenance, reducing the potential for bacteria build up.

Features include:

Anti-bacterial, high resilient and fire retardant foam

4 x lockable and 2x free wheel castors

Infection controlled, fully laminated powder coated base frame structure

Single piece of bent-ply for a supportive back cushion



Sleeper Chair

The Sleeper Chair's diverse capabilities suit a variety of healthcare preferences. Maximising maneuverability, the Sleeper Chair transitions between a comfortable lounge seat and a sleeper. 100mm / 3.9" castors provides accessibility to elevators, a perforated built in draw box enables infection control and offers guests and patients a place to store their personal items. The Sleeper Chair delivers exceptional functionality in a small footprint.

Features include:

Anti-bacterial, high resilient and fire retardant foam

Anti-fatigue, pressure relieving foam

Lockable castors for the front wheels

An easy to clean, full metal chassis with no exposed timber

Nylon constructed straps and wheels for ease of operation





Auto Recliner

The Auto Recliner offers patients and visitors the solace of home with a cohesive and inviting aesthetic. Inductive touch buttons empower the user with absolute maneuverability and 100mm / 3.9" castors enable smooth access to elevators.

Features include:

Anti-bacterial, high resilient and fire retardant foam

Anti-fatigue, pressure relieving foam

Heavy duty, twin wheel non marking castors with independent locking and kick release lock

An easy to clean, full metal chassis with no exposed timber

Lift up seat for easy cleaning and infection control

Front lockable castors



Manual Recliner

The Manual Recliner comes with a three way push on arm mechanism allowing patients and visitors the ability to fully recline, lean back or sit upright. Mobile support handles promote easy maneuvering and non marking castors feature an independent kick release lock with accessible foot operation.

Features include:

Anti-bacterial, high resilient and fire retardant foam

Anti-fatigue, pressure relieving foam

Lift up seat for easy cleaning and infection control

100mm / 3.9" castors for easy access to elevators

Full metal chassis with no exposed timber

Spring loaded kick board to avoid pinch points.



HD Recliner

The HD Recliner supports the crucial role family and friends play, assisting in the patient recovery process. A full range of reclining increments through the use of inductive touch buttons, allows each user maximum comfort and the lift up mechanism helps patients exit the recliner effortlessly, aiding a smooth transition from sit to stand.

Features include:

Anti-bacterial, high resilient and fire retardant foam

Anti-fatigue, pressure relieving foam

Lockable castors for the front wheels

An easy to clean, full metal chassis with no exposed timber

Spring loaded kick board to avoid pinch points

Castors for ease of maneuverability



Specifications

Sleeper Chair

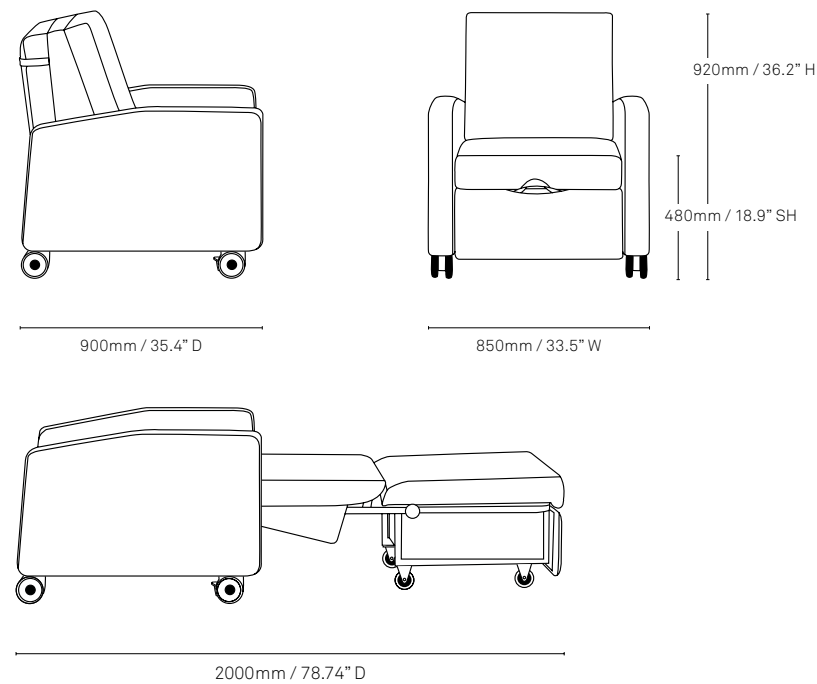

Weight load capacity
150kg / 330lb

Recommended finish
Fabric/Vinyl

Internal frame
Medium-density fibreboard (E0 MDF) plywood (19mm / 0.7"), KD (kiln dried) hardwood

Foam/filling materials
Flexible cellular polyurethane (HR 38-200, HR36-130, LR 38-80, CHGT 25-400, CHTI 35-500), anti-bacterial/fatigue and fire retardant foam

Mechanism
25.4 x 25.4 x 2.0WT mm black mild steel tube structure. Powder coated assembly unit with drawer box

Castors
100mm / 3.6" front brake loaded, rear freewheeling

Auto Recliner

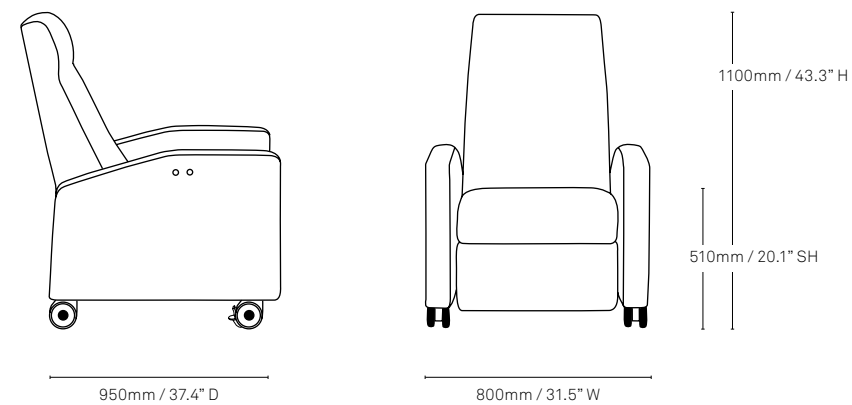

Weight load capacity
150kg / 330lb

Recommended finish
Fabric/Vinyl

Internal frame
Medium-density fibreboard (E0 MDF) plywood (19mm / 0.7"), KD (kiln dried) hardwood

Foam/filling materials
Flexible cellular polyurethane (HR52-60), (HR36-130), (HR35-600), (HR30-140), anti-bacterial/fatigue and fire retardant foam

Mechanism
Full 24" frame, G-30 power operated recliner mechanism with spring loaded kickboard

Castors
100mm / 3.9" front brake loaded, rear freewheeling

Manual Recliner

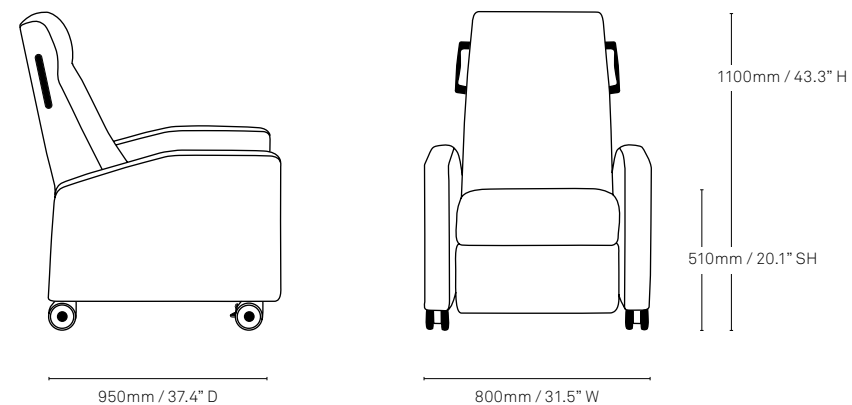

Weight load capacity
120kg / 265lb

Recommended finish
Fabric/Vinyl

Internal frame
Medium-density fibreboard (E0 MDF) plywood (19mm / 0.7"), KD (kiln dried) hardwood

Foam/filling materials
Flexible cellular polyurethane (HR52-60), (HR36-130), (HR35-600), (HR30-140), anti-bacterial/fatigue and fire retardant foam

Mechanism
Full 24" frame, G-30 manual recliner

Castors
100mm / 3.9" front brake loaded, rear freewheeling

HD Recliner

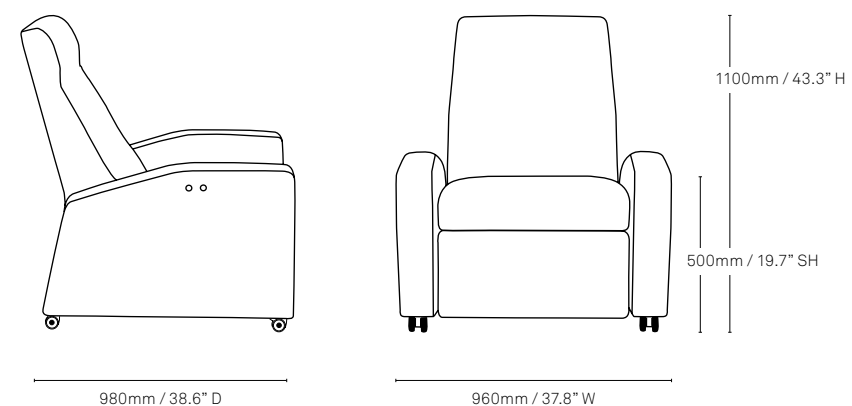

Weight load capacity
200kg / 440lb

Recommended finish
Fabric/Vinyl

Internal frame
Medium-density fibreboard (E0 MDF) plywood (19mm / 0.7"), KD (kiln dried) hardwood

Foam/filling materials
Flexible cellular polyurethane (HR52-60), (HR36-130), (HR35-600), (HR30-140), anti-bacterial/fatigue and fire retardant foam

Mechanism
Power operated recliner mechanism with spring loaded kickboard

Castors
50mm / 2" or 100mm / 3.9" front brake loaded, rear freewheeling

Day Bed

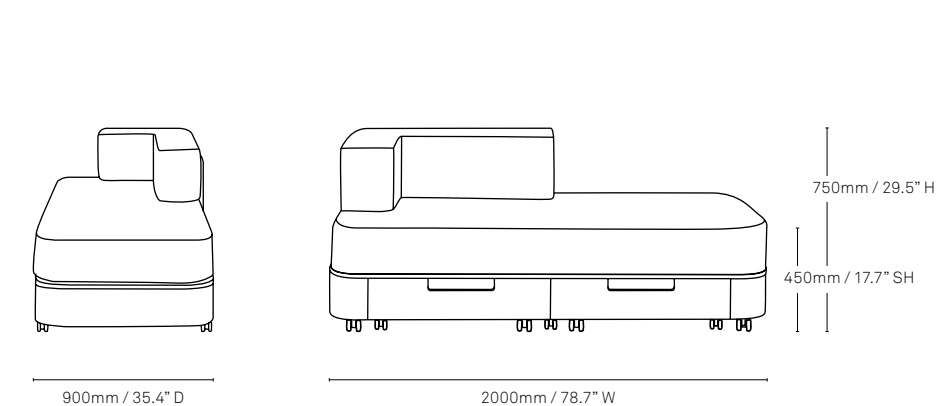

Weight load capacity
400kg / 880lb

Recommended finish
Fabric/Vinyl

Internal frame
Fully laminated frame with removable draws. 20mm / 0.8" finish chipboard (laminated) plywood

Foam/filling materials
Flexible cellular polyurethane (FR30-140, FR35-200), 100g / 0.2lb Dacron, anti-bacterial/fatigue and fire retardant foam

Mechanism
N/A

Castors
4 brakeload/10 freewheel. 50mm / 2" castors with a dynamic weight load capacity of 100kg / 220lb

Finishes

Designed with today's aesthetics in mind, our selection of healthcare grade fabrics are offered in a large selection of colours and shades. Soft and warming to the touch, this 100% polyester quality fabric is backed with high grade Nano-Tex, Durablock and BioAM material to ensure a long service life and testing to over 96,000 rubs.

FABRIC

FOCUS / Category 0

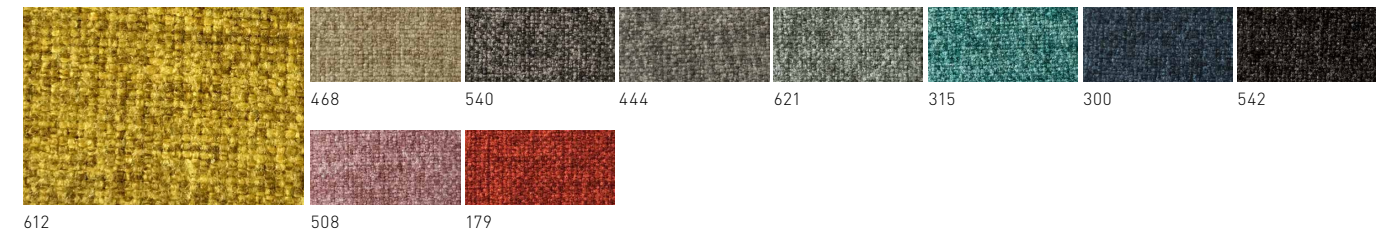

SILK / Category 1.5

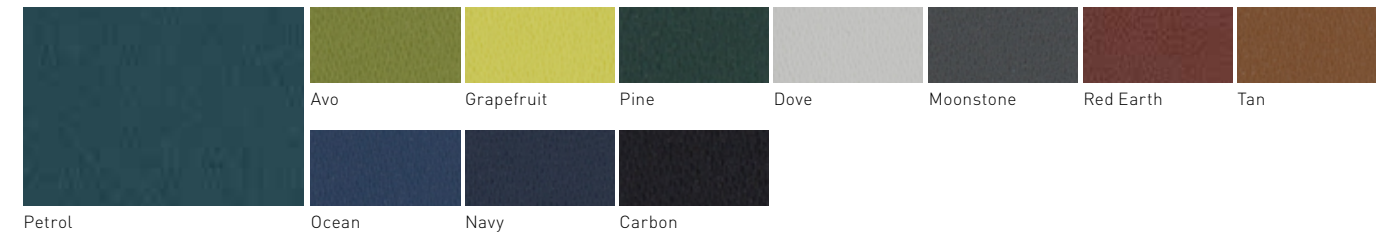

RAVE / Category 2



TRIESTE / Category 2.5

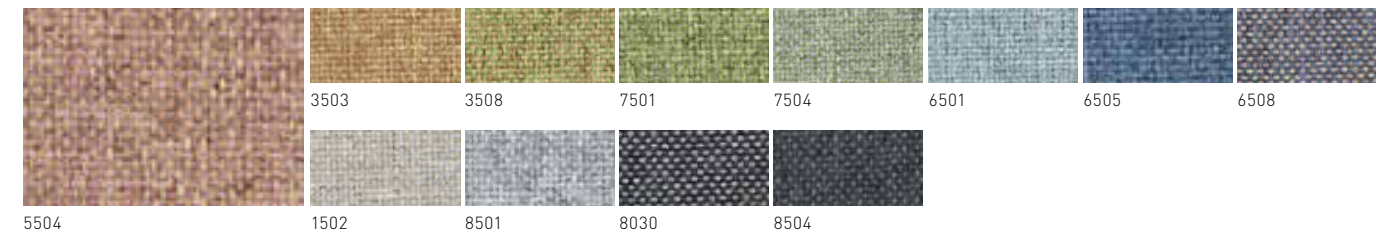

CATEGORY 0

Focus

CATEGORY 1.5

Silk

CATEGORY 2

Rave

CATEGORY 2.5

Trieste

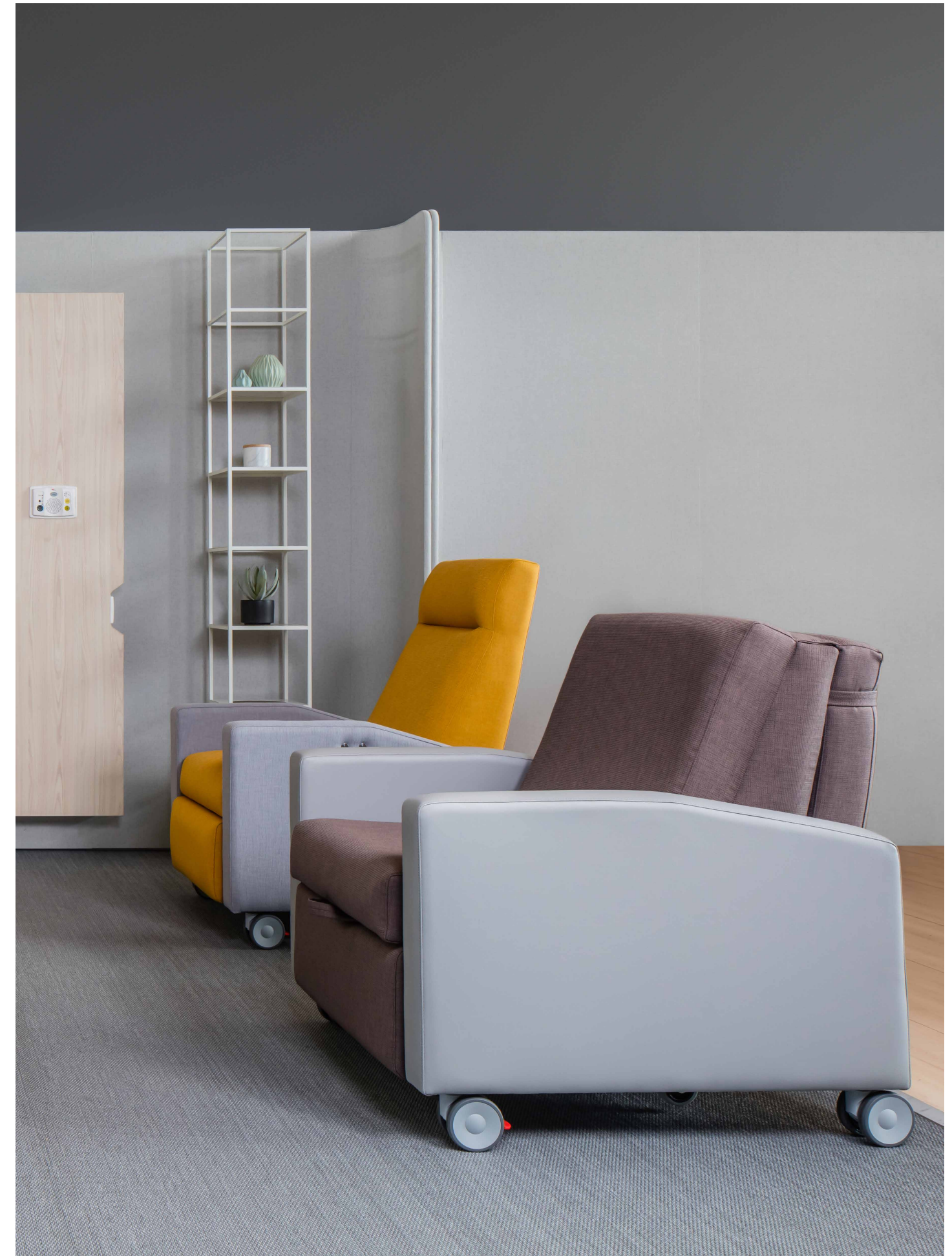



Ecology and sustainability

Schiavello's most important commitment to sustainability is the company-wide Environmental Management System under ISO 14001. The environmental design principles realised means we design for the environment, focusing on efficient energy use and minimum emissions, longevity and durability, re-use and recycling of our products.

Our principles of ME WE (Materials, Energy, Waste Emissions) give us a simple way to think about how our operations impact the environment.

Printed on an Australian made paper stock that is PEFC Certified and made from elemental chlorine-free bleached pulp sourced from sustainably managed forests and non-controversial sources. It is manufactured by an ISO 14001 certified mill using renewable energy sources.



FS 604920

EMS 604919

About Schiavello

Schiavello is a multi-disciplinary company dedicated to developing intelligent, inspiring, ecological and resilient solutions for the office, the home and public spaces.

Schiavello's concepts and products are developed in Australia by applying a design process that brings together the company's core design principles and engineering with the creativity of local and international designers.

The Schiavello head office and world-class manufacturing facilities are integral to our continually developing rich tapestry of knowledge. This knowledge ultimately assists us in informing the right solutions and tools for each organisation's needs and people, allowing us to consistently achieve our philosophy that 'Anything is possible'.

To find a Schiavello showroom or partner in your area, please visit [schiavellofurniture.com/find-us](https://www.schiavellofurniture.com/find-us)

All intellectual property rights and copyrights are reserved. Nothing contained in this brochure may be reproduced without written permission. Schiavello Group Pty Ltd reserves the right to change any or all details without prior notice. All dimensions stated within this document are nominal and/or approximate only and subject to variation. SCH/HCF02.0D-C